



## A0493

Punte a coltelli per spianare  
*Planing insert router bits*

### MATERIALE LAVORATO / MATERIALS

legno duro, mdf  
*hHrd wood, hHrd wood, mdf*

### IMPIEGO / FUNCTION

centro lavoro cnc  
*cnc router*

### DESCRIZIONE / DESCRIPTION

Punta a inserti per la lavorazione di spianatura su pannello. Particolarmente indicata per il livellamento del piano martire nelle lavorazioni di nesting su macchine a controllo cnc.

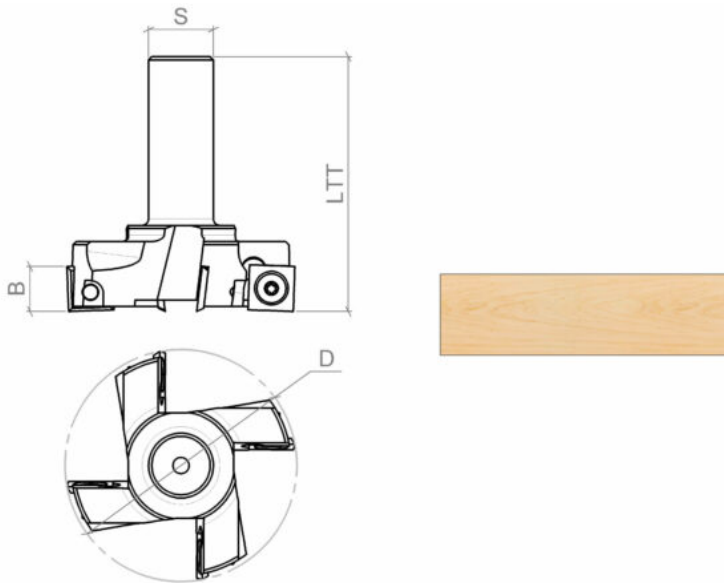

*Insert tool for flattening work on panels. Particularly suitable for leveling the mating surface in nesting operations on CNC controlled machines.*



### DATI TECNICI / TECHNICAL DATA

ART	COD	DRW	D	B	LTT	Z	ROT	S	GT
A0493	001	17046	50	14	85	3	Dx Rh	20	Assiale / Axial
A0493	002	85635	70	14	85	4	Dx Rh	20	Assiale / Axial
A0493	003	82553	80	14	85	4	Dx Rh	20	Assiale / Axial
A0493	004	33762	100	14	85	5	Dx Rh	20	Assiale / Axial
A0493	005	24878	120	14	85	5	Dx Rh	20	Assiale / Axial
A0493	006	33243	150	14	85	5	Dx Rh	25	Assiale / Axial

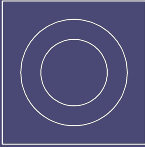
## RICAMBI / SPARE PARTS

COD.		QTY		QTY
A0493.001	A0540.001.3579	3	A1081.006.34357	3
A0493.002	A0540.001.3579	4	A1081.006.34357	4
A0493.003	A0540.001.3579	4	A1081.006.34357	4
A0493.004	A0540.001.3579	5	A1081.006.34357	5
A0493.005	A0540.001.3579	5	A1081.006.34357	5
A0493.006	A0540.001.3579	5	A1081.006.34357	5