



A0465

Punte a coltelli per contornare z=2+2 ri
Insert router cutters to edge z=2+2 ri

MATERIALE LAVORATO / MATERIALS

legno duro, legno tenero, mdf
*hHrd wood, hHrd wood, mdf, soft
 wood*

IMPIEGO / FUNCTION

centro lavoro cnc
cnc router

DESCRIZIONE / DESCRIPTION

Punta composta da Z=2 coltellini in HW(Hm integrale) spessore 1,5 mm. +2 Ri di testa per contornare. Particolarmente idonea per esecuzione di battute nel materiale da lavorare. Adatta a legni teneri, duri, incollati, truciolari, M.D.F ecc...

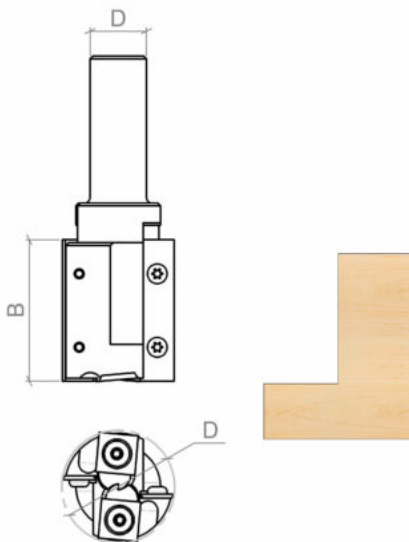

Router cutter to edge composed by Z=2 HW(integral tungsten carbide) inserts, 1,5 mm thickness. + Ri2. Particularly indicated to edges and rebates execution on material to work. Suitable for hard, soft, glued wood, chipboard, M.D.F. panels etc.



DATI TECNICI / TECHNICAL DATA

ART	COD	DRW	D	B	LTT	Z	ROT	S	GT
A0465	006	36453	40	50	110	2	Dx Rh	20	Dritta / Straight
A0465	010	52475	40	60	135	2	Dx Rh	20	Dritta / Straight
A0465	011	14709	40	80	145	2	Dx Rh	20	Assiale / Axial

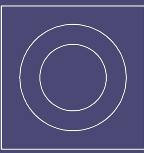
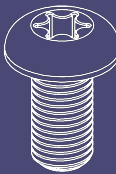
RICAMBI / SPARE PARTS

COD.		QTY		QTY		QTY		QTY
A0465.006	A0520.028.3364	2	A0540.001.3579	2	A1075.011.5437	4	A1081.006.34357	2
A0465.010	A0520.029.3365	2	A0540.001.3579	2	A1075.011.5437	4	A1081.006.34357	2
A0465.011	A0520.030.80935	2	A0540.001.3579	2	A1075.011.5437	4	A1075.011.34357	2