

## Utensili per pantografo - Router tools

A0410 - Punta elicoidali multitaglienti per forare e contornare <i>A0410 - Multicut spiral router bits to drill and edge</i>	pag. 1
A0415 - Punta elicoidali multitaglienti per contornare <i>A0415 - Multicut spiral router bits to edge</i>	pag. 2
A0440 - Punta sagomate saldobrasate <i>A0440 - Profiled router tools</i>	pag. 3
A0460 - Punta a coltelli per forare e contornare $z=2+1$ <i>A0460 - Insert router cutters to drill and edge <math>z=2+1</math></i>	pag. 7
A0465 - Punta a coltelli per contornare $z=2+2$ ri <i>A0465 - Insert router cutters to edge <math>z=2+2</math> ri</i>	pag. 9
A0470 - Punta a coltelli per smussi variabili <i>A0470 - Vari-angle bevelling insert router cutters</i>	pag. 11
A0471 - Punta a coltellini multitaglienti per contornare con coltelli 24,7x12x1,5 <i>A0471 - Insert multicut router cutters to edge 24,7x12x1,5 knives</i>	pag. 12
A0472 - Punta a coltellini multitaglienti per contornare con coltelli 20x12x1,5 <i>A0472 - Insert multicut router cutters to edge 20x12x1,5 knives</i>	pag. 14
A0473 - Punta a coltellini multitaglienti per contornare con coltelli 12x12x1,5 <i>A0473 - Insert multicut router cutters to edge 12x12x1,5 knives</i>	pag. 16
A2123 - Punta a coltellini multitaglienti per contornare con coltelli raggiati 15x15x2,5 <i>A2123 - Insert multicut router cutters to edge rounded 15x15x2,5 knives</i>	pag. 18
A0474 - Punta a coltellini multitaglienti con coltelli 14x14x2 <i>A0474 - Insert multicut router cutters to edge 14x14x2 knives</i>	pag. 20
A0396 - gruppo a coltellini per tenonare <i>A0396 - router cutters set for tenoning</i>	pag. 22
A0475 - Punta a coltelli sagomati $z=2$ inserto verticale <i>A0475 - Insert router cutters simple shapes <math>z=2</math></i>	pag. 24
A0476 - Punta a coltelli sagomati $z=2$ inserto orizzontale <i>A0476 - Profiled cnc router cutters with orizontal insert position</i>	pag. 26
A0477 - Punta a coltellini per giunzioni a $45^\circ$ <i>A0477 - Router cutters for joint <math>45^\circ</math></i>	pag. 27
A0482 - Punta a coltellini per piattabanda <i>A0482 - Panel rising router cutters</i>	pag. 29
A0484 - Punta a coltelli multisagoma jolly	pag. 30

A0484 - <i>Jolly multiprofile router cutters</i>	
A0485 - <i>Punte a coltellini multisagoma</i> <i>A0485 - Multiprofile insert router cutters</i>	pag. 33
A0486 - <i>Punte a coltellini per smussi e incisioni</i> <i>A0486 - Beveling and carving insert router cutters</i>	pag. 34
A0492 - <i>Punta portacoltelli sagomata semisferica</i> <i>A0492 - Bull nose insert router bits</i>	pag. 36
A0491 - <i>Punta sagomata per squadratura e contornatura a 1/4 di tondo concavo</i> <i>A0491 - Quarter circle squaring and contouring insert router bits</i>	pag. 38
A0481 - <i>Punte a coltelli per quarti di tondo concavo</i> <i>A0481 - Quarter circle insert router bits</i>	pag. 40
A0488 - <i>Punte a coltelli per mezzo tondo</i> <i>A0488 - Half circle insert router bits</i>	pag. 42
A0493 - <i>Punte a coltelli per spianare</i> <i>A0493 - Planing insert router bits</i>	pag. 44
A2149 - <i>Punte per contornatura registrabile</i> <i>A2149 - Adjustabel contouring router tool</i>	pag. 46
A0494 - <i>Punte a coltelli per canali a v</i> <i>A0494 - V groove insert router bits</i>	pag. 47
A0490 - <i>Set completo per esecuzione antina in legno massello</i> <i>A0490 - Insert router cutter set for solid wood door exec.</i>	pag. 49
A2124 - <i>Punte per esecuzione sede maniglia</i> <i>A2124 - Handle seat router tools</i>	pag. 50
A2128 - <i>Punte portacoltelli per raggare spigoli</i> <i>A2128 - Router insert tools for rounfing edges</i>	pag. 52
A2141 - <i>Punta portacoltelli a palla</i> <i>A2141 - router cutter ball shape</i>	pag. 54
A2137 - <i>Gruppo lama con attacco cilindrico</i> <i>A2137 - Saw blade set with cylindrical shank</i>	pag. 56
A0495 - <i>Set completo per esecuzione antina in m.d.f.</i> <i>A0495 - Insert router cutter set for m.d.f. door exec.</i>	pag. 57
A2134 - <i>Kit completo per lavorazione sedie in legno su macchina cnc</i> <i>A2134 - Complete kit for wooden chairs processing on cnc machine</i>	pag. 59
A2140 - <i>Kit completo startup per macchina cnc</i> <i>A2140 - Complete kit startup for cnc machine</i>	pag. 61



## A0410

Punte elicoidali multitaglienti per forare e contornare

*Multicut spiral router bits to drill and edge*

### MATERIALE LAVORATO / MATERIALS

legno duro, legno tenero  
*hHrd wood, hHrd wood, soft wood*

### IMPIEGO / FUNCTION

centro lavoro cnc  
*cnc router*

### DESCRIZIONE / DESCRIPTION

Punte a 3 o 6 taglienti in Hc (Hm riportato) frazionati. Questa esecuzione consente una notevole riduzione della rumorosità e dell'assorbimento di energia e permette un notevole aumento della velocità di avanzamento. Particolarmente indicata per eseguire lavorazioni di contornatura permette l'entrata in rampa.

*Router bits with 3 or 6 fractioned cutting edges in Hc (brazed tungsten carbide), positioned on a spiral design. This execution allows a remarkable noise and energy reduction and permits a considerable increase of feed speed. Suitable for ramp entry operations on soft wood, hard wood and plywood.*

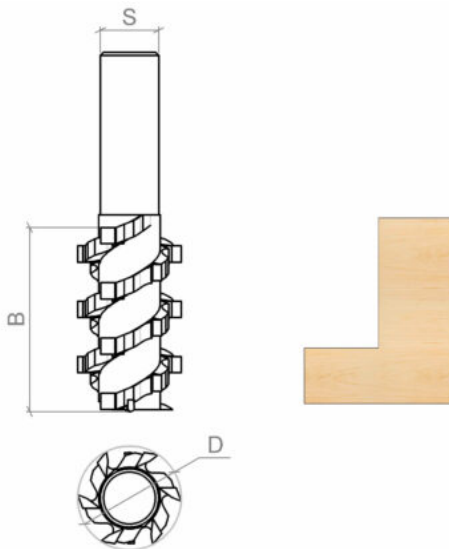

### DATI TECNICI / TECHNICAL DATA

ART	COD	DRW	D	B	Z	S	A	GT
A0410	001	5901	20	45	3	20	8	Multitaglienti / Multicut
A0410	006	7355	30	60	6	20	21	Multitaglienti / Multicut
A0410	010	36885	30	80	6	20	27	Multitaglienti / Multicut
A0410	011	52470	30	100	6	20	34	Multitaglienti / Multicut
A0410	012	52471	30	120	6	20	41	Multitaglienti / Multicut

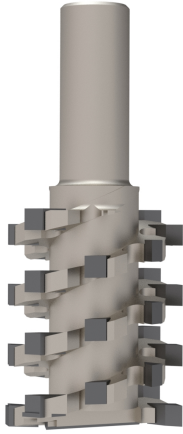

## A0415

Punte elicoidali multitaglienti per contornare  
*Multicut spiral router bits to edge*

### MATERIALE LAVORATO / MATERIALS

legno duro, legno tenero, mdf  
*hHrd wood, hHrd wood, mdf, soft  
wood*

### IMPIEGO / FUNCTION

centro lavoro cnc  
*cnc router*

### DESCRIZIONE / DESCRIPTION

Punte a 8 taglienti in Hc (Hm riportato) frazionati. Questa esecuzione consente una notevole diminuzione della rumorosità e dell'assorbimento di energia e permette di aumentare notevolmente la velocità di avanzamento. Particolarmente indicata per eseguire lavorazioni di contornatura su legni teneri, duri.

*Router bits with 8 fractioned cutting edges in Hc (brazed tungsten carbide), positioned on a spiral design. This execution allows a remarkable noise and energy reduction and permits a considerable increase of feed speed. Suitable for edging operations, on soft and hard wood, plywood.*

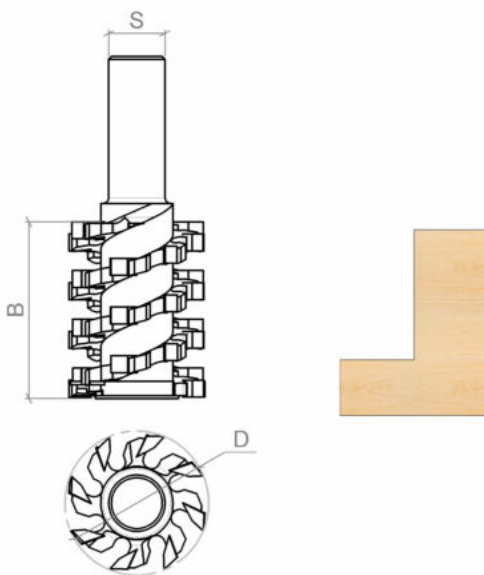

### DATI TECNICI / TECHNICAL DATA

ART	COD	DRW	D	B	Z	S	A	GT
A0415	001	29133	50	60	8	20	27	Multitaglienti / Multicut
A0415	004	33668	50	100	8	20	46	Multitaglienti / Multicut
A0415	005	6357	50	120	8	20	55	Multitaglienti / Multicut

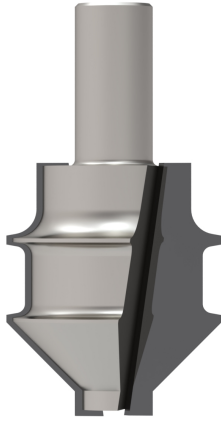

## A0440

Punte sagomate saldobrasate  
Profiled router tools

### DESCRIZIONE / DESCRIPTION

Frese saldobrasate a disegno. L'esecuzione standard è a due taglienti (z=2) ma è possibile quando la sagoma lo permetta esecuzione a tre taglienti (z=3) con un aumento del prezzo del 25%

*Custom brazed cutters. The standard execution is with two cutting edges (z=2) but it is possible when the shape allows it execution with three cutting edges (z=3) with a price increase of 25%*

### VARIANTI / OPTIONS

E' possibile montare come opzione, un cuscinetto per seguire forme complesse (prezzo a preventivo)

*As an option, it is possible to mount a bearing to follow complex shapes (price on estimate)*

### DATI TECNICI / TECHNICAL DATA

ART	COD	D	B	Z	ROT	S
A0440	201	15	15	2	Dx - Rh	12
A0440	202	20	15	2	Dx - Rh	12
A0440	203	25	15	2	Dx - Rh	12
A0440	204	30	15	2	Dx - Rh	12
A0440	205	35	15	2	Dx - Rh	12
A0440	206	40	15	2	Dx - Rh	12
A0440	207	50	15	2	Dx - Rh	12
A0440	208	60	15	2	Dx - Rh	12
A0440	209	70	15	2	Dx - Rh	12
A0440	210	80	15	2	Dx - Rh	12
A0440	211	15	20	2	Dx - Rh	12
A0440	212	20	20	2	Dx - Rh	12
A0440	213	25	20	2	Dx - Rh	12
A0440	214	30	20	2	Dx - Rh	12
A0440	215	35	20	2	Dx - Rh	12
A0440	216	40	20	2	Dx - Rh	12
A0440	217	50	20	2	Dx - Rh	12
A0440	218	60	20	2	Dx - Rh	12
A0440	219	70	20	2	Dx - Rh	12
A0440	220	15	25	2	Dx - Rh	12
A0440	221	20	25	2	Dx - Rh	12
A0440	222	25	25	2	Dx - Rh	12
A0440	223	30	25	2	Dx - Rh	12
A0440	224	35	25	2	Dx - Rh	12
A0440	225	40	25	2	Dx - Rh	12
A0440	226	50	25	2	Dx - Rh	12
A0440	227	60	25	2	Dx - Rh	12
A0440	228	70	25	2	Dx - Rh	12
A0440	229	15	30	2	Dx - Rh	12

ART	COD	D	B	Z	ROT	S
A0440	230	20	30	2	Dx - Rh	12
A0440	231	25	30	2	Dx - Rh	12
A0440	232	30	30	2	Dx - Rh	12
A0440	233	35	30	2	Dx - Rh	12
A0440	234	40	30	2	Dx - Rh	12
A0440	235	50	30	2	Dx - Rh	12
A0440	236	60	30	2	Dx - Rh	12
A0440	237	15	35	2	Dx - Rh	12
A0440	238	20	35	2	Dx - Rh	12
A0440	239	25	35	2	Dx - Rh	12
A0440	240	30	35	2	Dx - Rh	12
A0440	241	35	35	2	Dx - Rh	12
A0440	242	40	35	2	Dx - Rh	12
A0440	243	50	35	2	Dx - Rh	12
A0440	301	15	15	2	Dx - Rh	16
A0440	302	20	15	2	Dx - Rh	16
A0440	303	25	15	2	Dx - Rh	16
A0440	304	30	15	2	Dx - Rh	16
A0440	305	35	15	2	Dx - Rh	16
A0440	306	40	15	2	Dx - Rh	16
A0440	307	50	15	2	Dx - Rh	16
A0440	308	60	15	2	Dx - Rh	16
A0440	309	70	15	2	Dx - Rh	16
A0440	310	80	15	2	Dx - Rh	16
A0440	311	15	20	2	Dx - Rh	16
A0440	312	20	20	2	Dx - Rh	16
A0440	313	25	20	2	Dx - Rh	16
A0440	314	30	20	2	Dx - Rh	16
A0440	315	35	20	2	Dx - Rh	16
A0440	316	40	20	2	Dx - Rh	16
A0440	317	50	20	2	Dx - Rh	16
A0440	318	60	20	2	Dx - Rh	16
A0440	319	70	20	2	Dx - Rh	16
A0440	320	15	25	2	Dx - Rh	16
A0440	321	20	25	2	Dx - Rh	16
A0440	322	25	25	2	Dx - Rh	16
A0440	323	30	25	2	Dx - Rh	16
A0440	324	35	25	2	Dx - Rh	16
A0440	325	40	25	2	Dx - Rh	16
A0440	326	50	25	2	Dx - Rh	16
A0440	327	60	25	2	Dx - Rh	16
A0440	328	70	25	2	Dx - Rh	16
A0440	329	15	30	2	Dx - Rh	16
A0440	330	20	30	2	Dx - Rh	16
A0440	331	25	30	2	Dx - Rh	16
A0440	332	30	30	2	Dx - Rh	16
A0440	333	35	30	2	Dx - Rh	16
A0440	334	40	30	2	Dx - Rh	16
A0440	335	50	30	2	Dx - Rh	16
A0440	336	60	30	2	Dx - Rh	16
A0440	337	15	35	2	Dx - Rh	16
A0440	338	20	35	2	Dx - Rh	16
A0440	339	25	35	2	Dx - Rh	16
A0440	340	30	35	2	Dx - Rh	16
A0440	341	35	35	2	Dx - Rh	16
A0440	342	40	35	2	Dx - Rh	16

ART	COD	D	B	Z	ROT	S
A0440	343	50	35	2	Dx - Rh	16
A0440	344	60	35	2	Dx - Rh	16
A0440	345	70	35	2	Dx - Rh	16
A0440	346	15	40	2	Dx - Rh	16
A0440	347	20	40	2	Dx - Rh	16
A0440	348	25	40	2	Dx - Rh	16
A0440	349	30	40	2	Dx - Rh	16
A0440	350	35	40	2	Dx - Rh	16
A0440	351	40	40	2	Dx - Rh	16
A0440	352	50	40	2	Dx - Rh	16
A0440	353	60	40	2	Dx - Rh	16
A0440	401	15	15	2	Dx - Rh	20
A0440	402	20	15	2	Dx - Rh	20
A0440	403	25	15	2	Dx - Rh	20
A0440	404	30	15	2	Dx - Rh	20
A0440	405	35	15	2	Dx - Rh	20
A0440	406	40	15	2	Dx - Rh	20
A0440	407	50	15	2	Dx - Rh	20
A0440	408	60	15	2	Dx - Rh	20
A0440	409	70	15	2	Dx - Rh	20
A0440	410	80	15	2	Dx - Rh	20
A0440	411	15	20	2	Dx - Rh	20
A0440	412	20	20	2	Dx - Rh	20
A0440	413	25	20	2	Dx - Rh	20
A0440	414	30	20	2	Dx - Rh	20
A0440	415	35	20	2	Dx - Rh	20
A0440	416	40	20	2	Dx - Rh	20
A0440	417	50	20	2	Dx - Rh	20
A0440	418	60	20	2	Dx - Rh	20
A0440	419	70	20	2	Dx - Rh	20
A0440	420	80	20	2	Dx - Rh	20
A0440	421	15	25	2	Dx - Rh	20
A0440	422	20	25	2	Dx - Rh	20
A0440	423	25	25	2	Dx - Rh	20
A0440	424	30	25	2	Dx - Rh	20
A0440	425	35	25	2	Dx - Rh	20
A0440	426	40	25	2	Dx - Rh	20
A0440	427	50	25	2	Dx - Rh	20
A0440	428	60	25	2	Dx - Rh	20
A0440	429	70	25	2	Dx - Rh	20
A0440	430	80	25	2	Dx - Rh	20
A0440	431	15	30	2	Dx - Rh	20
A0440	432	20	30	2	Dx - Rh	20
A0440	433	25	30	2	Dx - Rh	20
A0440	434	30	30	2	Dx - Rh	20
A0440	435	35	30	2	Dx - Rh	20
A0440	436	40	30	2	Dx - Rh	20
A0440	437	50	30	2	Dx - Rh	20
A0440	438	60	30	2	Dx - Rh	20
A0440	439	70	30	2	Dx - Rh	20
A0440	440	80	30	2	Dx - Rh	20
A0440	441	15	35	2	Dx - Rh	20
A0440	442	20	35	2	Dx - Rh	20
A0440	443	25	35	2	Dx - Rh	20
A0440	444	30	35	2	Dx - Rh	20
A0440	445	35	35	2	Dx - Rh	20

ART	COD	D	B	Z	ROT	S
A0440	446	40	35	2	Dx - Rh	20
A0440	447	50	35	2	Dx - Rh	20
A0440	448	60	35	2	Dx - Rh	20
A0440	449	70	35	2	Dx - Rh	20
A0440	450	80	35	2	Dx - Rh	20
A0440	451	15	40	2	Dx - Rh	20
A0440	452	20	40	2	Dx - Rh	20
A0440	453	25	40	2	Dx - Rh	20
A0440	454	30	40	2	Dx - Rh	20
A0440	455	35	40	2	Dx - Rh	20
A0440	456	40	40	2	Dx - Rh	20
A0440	457	50	40	2	Dx - Rh	20
A0440	458	60	40	2	Dx - Rh	20
A0440	459	70	40	2	Dx - Rh	20
A0440	460	80	40	2	Dx - Rh	20
A0440	461	15	50	2	Dx - Rh	20
A0440	462	20	50	2	Dx - Rh	20
A0440	463	25	50	2	Dx - Rh	20
A0440	464	30	50	2	Dx - Rh	20
A0440	465	35	50	2	Dx - Rh	20
A0440	466	40	50	2	Dx - Rh	20
A0440	467	50	50	2	Dx - Rh	20
A0440	468	60	50	2	Dx - Rh	20
A0440	469	70	50	2	Dx - Rh	20
A0440	470	80	50	2	Dx - Rh	20
A0440	471	15	60	2	Dx - Rh	20
A0440	472	20	60	2	Dx - Rh	20
A0440	473	25	60	2	Dx - Rh	20
A0440	474	30	60	2	Dx - Rh	20
A0440	475	35	60	2	Dx - Rh	20
A0440	476	40	60	2	Dx - Rh	20
A0440	477	50	60	2	Dx - Rh	20
A0440	478	60	60	2	Dx - Rh	20
A0440	479	70	60	2	Dx - Rh	20
A0440	480	80	60	2	Dx - Rh	20





## A0460

Punte a coltelli per forare e contornare z=2+1  
*Insert router cutters to drill and edge z=2+1*

### MATERIALE LAVORATO / MATERIALS

legno duro, legno tenero, mdf  
*hHrd wood, hHrd wood, mdf, soft  
 wood*

### IMPIEGO / FUNCTION

centro lavoro cnc  
*cnc router*

### DESCRIZIONE / DESCRIPTION

Punta composta da Z=2 coltellini in HW(Hm integrale) spessore 1,5 mm. + Z=1 in Hc (Hm riportato) di testa per forare e contornare. Particolarmente idonea per esecuzione di foratura e contornatura di legni teneri, duri, incollati, truciolari, M.D.F ecc.

*Router cutter to drill and edge composed by Z=2 HW(integral tungsten carbide) inserts, 1,5 mm thickness. + Z=1 in Hc(brazed tungsten carbide) at the top Particularly indicated for executions of drilling and edging on hard, soft, glued wood, chipboard, M.D.F. panels etc.*

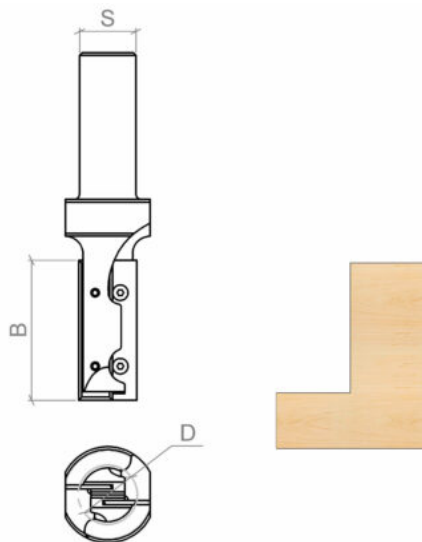

### DATI TECNICI / TECHNICAL DATA

ART	COD	DRW	D	B	Z	ROT	S
A0460	001	15794	21	50	2+1	Dx Rh	20
A0460	002	30508	22	50	2+1	Dx Rh	20
A0460	003	40975	23	50	2+1	Dx Rh	20
A0460	004	52474	24	50	2+1	Dx Rh	20
A0460	005	40977	25	50	2+1	Dx Rh	20
A0460	006	40979	26	50	2+1	Dx Rh	20
A0460	007	40981	27	50	2+1	Dx Rh	20
A0460	008	40983	28	50	2+1	Dx Rh	20
A0460	009	40985	29	50	2+1	Dx Rh	20
A0460	010	50925	30	50	2+1	Dx Rh	20

## RICAMBI / SPARE PARTS

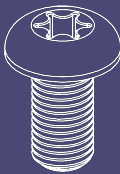
COD.		QTY		QTY
A0460.001	A0520.028.3364	2	A1075.011.5437	4
A0460.002	A0520.028.3364	2	A1075.011.5437	4
A0460.003	A0520.028.3364	2	A1075.011.5437	4
A0460.004	A0520.028.3364	2	A1075.011.5437	4
A0460.005	A0520.028.3364	2	A1075.011.5437	4
A0460.006	A0520.028.3364	2	A1075.011.5437	4
A0460.007	A0520.028.3364	2	A1075.011.5437	4
A0460.008	A0520.028.3364	2	A1075.011.5437	4
A0460.009	A0520.028.3364	2	A1075.011.5437	4
A0460.010	A0520.028.3364	2	A1075.011.5437	4



## A0465

Punte a coltelli per contornare z=2+2 ri  
*Insert router cutters to edge z=2+2 ri*

### MATERIALE LAVORATO / MATERIALS

legno duro, legno tenero, mdf  
*hHrd wood, hHrd wood, mdf, soft  
 wood*

### IMPIEGO / FUNCTION

centro lavoro cnc  
*cnc router*

### DESCRIZIONE / DESCRIPTION

Punta composta da Z=2 coltellini in HW(Hm integrale) spessore 1,5 mm. +2 Ri di testa per contornare. Particolarmente idonea per esecuzione di battute nel materiale da lavorare. Adatta a legni teneri, duri, incollati, truciolari, M.D.F ecc...

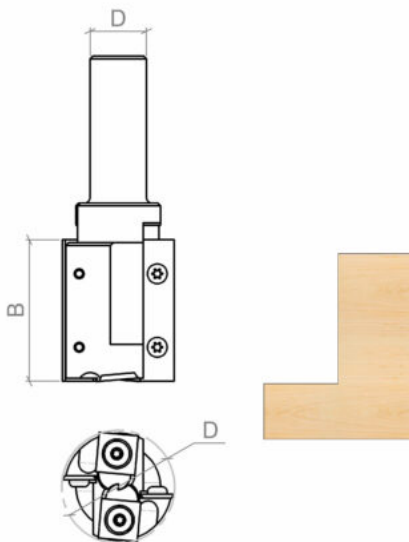

*Router cutter to edge composed by Z=2 HW(integral tungsten carbide) inserts, 1,5 mm thickness. + Ri2. Particularly indicated to edges and rebates execution on material to work. Suitable for hard, soft, glued wood, chipboard, M.D.F. panels etc.*



### DATI TECNICI / TECHNICAL DATA

ART	COD	DRW	D	B	LTT	Z	ROT	S	GT
A0465	006	36453	40	50	110	2	Dx Rh	20	Dritta / Straight
A0465	010	52475	40	60	135	2	Dx Rh	20	Dritta / Straight
A0465	011	14709	40	80	145	2	Dx Rh	20	Assiale / Axial

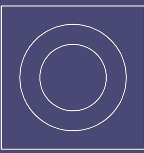
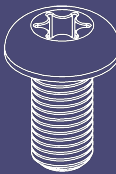
## RICAMBI / SPARE PARTS

COD.		QTY		QTY		QTY		QTY
A0465.006	A0520.028.3364	2	A0540.001.3579	2	A1075.011.5437	4	A1081.006.34357	2
A0465.010	A0520.029.3365	2	A0540.001.3579	2	A1075.011.5437	4	A1081.006.34357	2
A0465.011	A0520.030.80935	2	A0540.001.3579	2	A1075.011.5437	4	A1075.011.34357	2



## A0470

Punte a coltelli per smussi variabili

*Vari-angle bevelling insert router cutters*

### MATERIALE LAVORATO / MATERIALS

legno duro, legno tenero, mdf  
*hHrd wood, mdf, soft wood*

### IMPIEGO / FUNCTION

centro lavoro cnc  
*cnc router*

### DESCRIZIONE / DESCRIPTION

punta Z=2 per smussi variabili da 0°;+85°;-85° con coltellini reversibili in HW (Hm integrale), spessore 1,5 mm. Utensile adatto per lavorazione su tutti i tipi di legno, truciolari, M.D.F. ecc...

*Z=2 insert cutters for adjustable bevel angle from 0°;+85°;-85°, with HW (integral tungsten carbide ) reversible inserts, 1,5 mm thickness. Suitable for all type of wood, chipboard, M.D.F. Etc...*

### DATI TECNICI / TECHNICAL DATA

ART	COD	DRW	D	B	Z	ROT	S
A0470	001	52476	100	40	2	Dx Rh	20
A0470	002	52477	100	50	2	Dx Rh	20



## A0471

Punte a coltellini multitaglienti per contornare  
con coltelli 24,7x12x1,5

*Insert multicut router cutters to edge  
24,7x12x1,5 knives*

### MATERIALE LAVORATO / MATERIALS

legno duro, legno tenero, mdf  
*hHrd wood, hHrd wood, mdf, soft  
wood*

### IMPIEGO / FUNCTION

centro lavoro cnc  
*cnc router*

### DESCRIZIONE / DESCRIPTION

Punta composta da un corpo in lega leggera montato su alberino in acciaio. I coltellini in HW(Hm integrale) spessore 1,5 mm sono posti in modo elicoidale. Particolarmente idonea per esecuzione di contornatura e battute nel materiale da lavorare. Per lavori di semifinitura. Adatta a legni teneri, duri, incollati, truciolari, M.D.F ecc...

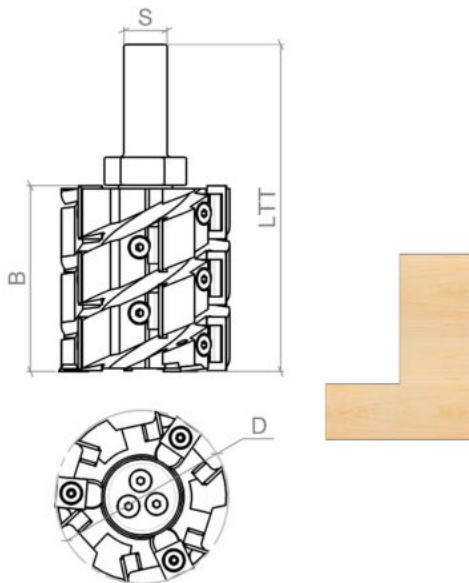

*Router cutter composed of a body in light alloy mounted on arbour in steel. The HW(Hm integral tungsten carbide) reversible inserts 1,5 mm thickness are positioned helically. Particularly suitable for executions of edging and rebates on the material to work. For semifinish operations. Suitable for hard, soft woods, chipboard, M.D.F etc....*



### DATI TECNICI / TECHNICAL DATA

ART	COD	DRW	D	B	LTT	Z	RI	ROT	S	GT
A0471	001	15757	80	85	150	6	3	Dx Rh	20	Multitaglienti / Multicut
A0471	002	42265	80	120	180	6	3	Dx Rh	20	Multitaglienti / Multicut

**RICAMBI / SPARE PARTS**

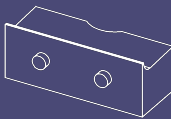
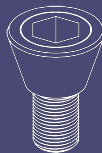
COD.		QTY		QTY		QTY		QTY
A0471.001	A0535.003.3575	15	A0540.001.3579	3	A1057.023.15752	15	A1078.012.14700	15
A0471.002	A0535.003.3575	21	A0540.001.3579	3	A1057.023.15752	21	A1078.012.14700	21

COD.		QTY
A0471.001	A1081.005.34356	3
A0471.002	A1081.005.34356	3



## A0472

Punte a coltellini multitaglienti per contornare con coltelli 20x12x1,5

*Insert multicut router cutters to edge 20x12x1,5 knives*

### MATERIALE LAVORATO / MATERIALS

legno duro, legno tenero, mdf  
hHrd wood, hHrd wood, mdf, soft wood

### IMPIEGO / FUNCTION

centro lavoro cnc  
cnc router

### DESCRIZIONE / DESCRIPTION

Punta multitagliente a coltellini in HW (Hm integrale) spessore 1,5 mm posti in modo elicoidale. Particolarmente idonea per esecuzione di contornatura nel materiale da lavorare. Per lavori di semifinitura. Adatta a legni teneri, duri, incollati, truciolari, M.D.F ecc.

*Insert multicut router cutter with HW(Hm integral tungsten carbide) reversible inserts 1,5 mm thickness positioned helically. Particularly suitable for executions of edging on the material to work. For semifinish operations. Suitable for hard, soft woods, chipboard, M.D.F etc....*

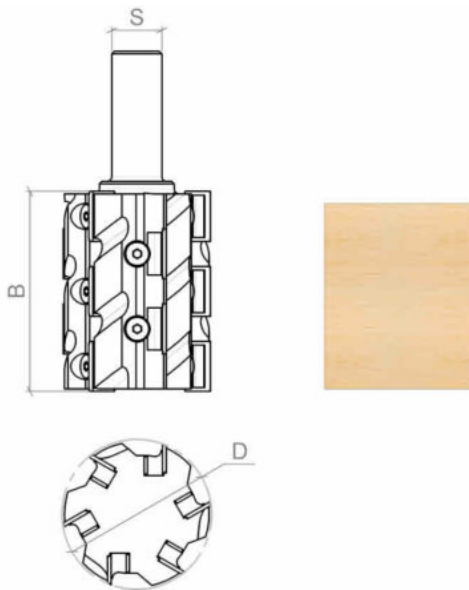

### DATI TECNICI / TECHNICAL DATA

ART	COD	DRW	D	B	LTT	Z	ROT	S	GT
A0472	001	14698	60	80	150	6	Dx Rh	20	Multitaglienti / Multicut

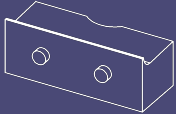
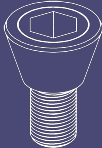

## RICAMBI / SPARE PARTS

COD.		QTY		QTY		QTY
A0472.001	A0535.001.32929	15	A1057.023.15752	15	A1078.012.14700	15

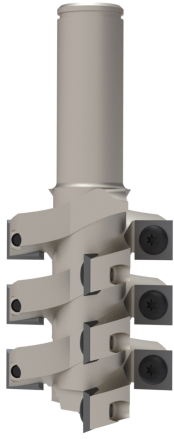

## A0473

Punte a coltellini multitaglienti per contornare con coltelli 12x12x1,5

*Insert multicut router cutters to edge 12x12x1,5 knives*

### MATERIALE LAVORATO / MATERIALS

legno duro, legno tenero, mdf  
hHrd wood, hHrd wood, mdf, soft wood

### IMPIEGO / FUNCTION

centro lavoro cnc  
cnc router

### DESCRIZIONE / DESCRIPTION

Punta multitagliente a coltellini in HW (Hm integrale) spessore 1,5 mm posti in modo elicoidale. Particolarmente idonea per esecuzione di contornatura nel materiale da lavorare. Per lavori di sgrossatura. Adatta a legni teneri, duri, incollati, truciolari, M.D.F ecc.

*Insert multicut router cutter with HW(Hm integral tungsten carbide) reversible inserts 1,5 mm thickness positioned helically. Particularly suitable for executions of edging on the material to work. For roughing operations. Suitable for hard, soft woods, chipboard, M.D.F etc....*

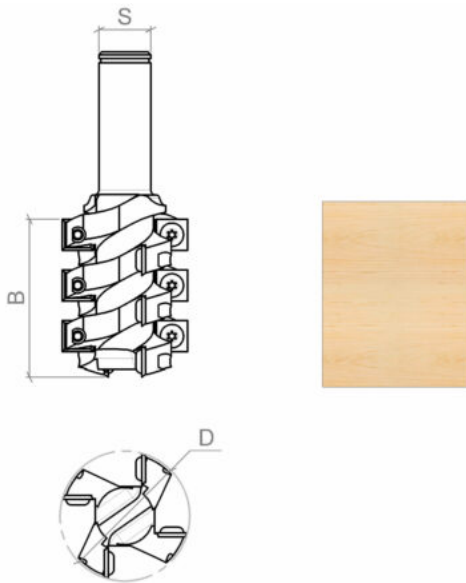

### DATI TECNICI / TECHNICAL DATA

ART	COD	DRW	D	B	LTT	Z	ROT	S	A	GT
A0473	001	38329	50	60	125	4	Dx Rh	20	12	Multitaglienti / Multicut
A0473	002	52478	50	80	145	4	Dx Rh	20	16	Multitaglienti / Multicut
A0473	003	52479	50	100	165	4	Dx Rh	20	20	Multitaglienti / Multicut

## RICAMBI / SPARE PARTS

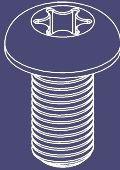
COD.		QTY		QTY
A0473.001	A0520.020.3354	12	A1075.015.3452	12
A0473.002	A0520.020.3354	18	A1075.015.3452	18
A0473.003	A0520.020.3354	24	A1075.015.3452	24



## A2123

Punte a coltellini multitaglienti per contornare con coltelli raggiati 15x15x2.5

*Insert multicut router cutters to edge rounded 15x15x2,5 knives*

### MATERIALE LAVORATO / MATERIALS

legno duro, legno tenero, mdf  
hHrd wood, hHrd wood, mdf, soft wood

### IMPIEGO / FUNCTION

centro lavoro cnc  
cnc router

### DESCRIZIONE / DESCRIPTION

Punta multitagliente a coltellini in HW (Hm integrale) spessore 2,5 mm posti in modo elicoidale. Particolarmente idonea per esecuzione di contornatura nel materiale da lavorare. Per lavori di semi finitura. Adatta a legni teneri, duri, incollati, truciolari, M.D.F ecc.

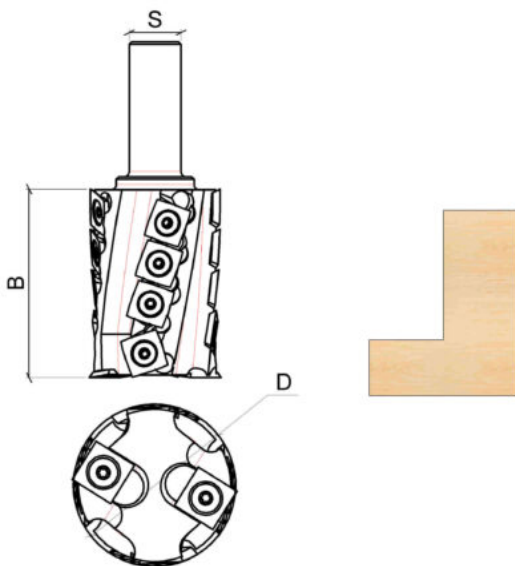

*Insert multicut router cutter with HW(Hm integral tungsten carbide) reversible inserts 2,5 mm thickness positioned helically. Particularly suitable for executions of edging on the material to work. For semifinish operations. Suitable for hard, soft woods, chipboard, M.D.F etc....*



### DATI TECNICI / TECHNICAL DATA

ART	COD	DRW	D	B	LTT	Z	RI	ROT	S	GT
A2123	001	83346	50	73	133	4	2	Dx Rh	20	Multitagliente / Multicut
A2123	002	94900	50	100	165	4	2	Dx Rh	25	Multitagliente / Multicut

## RICAMBI / SPARE PARTS

COD.		QTY		QTY		QTY
A2123.001	A0547.003.27062	16	A0540.001.3579	2	A1081.006.34357	18
A2123.002	A0547.003.27062	24	A0540.001.3579	2	A1081.006.34357	26



## A0474

Punte a coltellini multitaglienti con coltelli  
14x14x2

*Insert multicut router cutters to edge 14x14x2  
knives*

### MATERIALE LAVORATO / MATERIALS

legno duro, legno tenero, mdf  
*hHrd wood, hHrd wood, mdf, soft  
wood*

### IMPIEGO / FUNCTION

centro lavoro cnc  
*cnc router*

### DESCRIZIONE / DESCRIPTION

Punta multitagliente a coltellini in HW (Hm integrale) spessore 2 mm posti in modo elicoidale. Particolarmente idonea per esecuzione di contornatura nel materiale da lavorare. Per lavori di semi finitura. Adatta a legni teneri, duri, incollati, truciolari, M.D.F ecc.

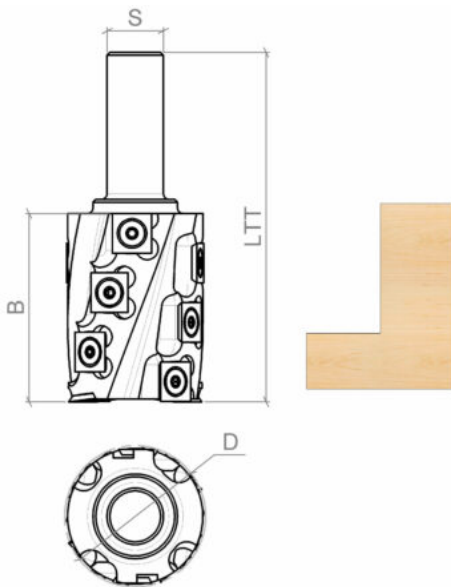

*Insert multicut router cutter with HW(Hm integral tungsten carbide) reversible inserts 2 mm thickness positioned helically. Particularly suitable for executions of edging on the material to work. For semifinish operations. Suitable for hard, soft woods, chipboard, M.D.F etc....*



### DATI TECNICI / TECHNICAL DATA

ART	COD	DRW	D	B	LTT	Z	ROT	S	GT
A0474	001	47581	50	65	125	4	Dx Rh	20	Multitaglienti / Multicut
A0474	002	52480	50	85	145	4	Dx Rh	20	Multitaglienti / Multicut
A0474	003	52481	50	105	165	4	Dx Rh	20	Multitaglienti / Multicut
A0474	004	95294	50	145	207	4	Dx Rh	25	Multitaglienti / Multicut

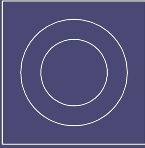
## RICAMBI / SPARE PARTS

COD.		QTY		QTY
A0474.001	A0540.001.3579	14	A1081.006.34357	14
A0474.002	A0540.001.3579	18	A1081.006.34357	18
A0474.003	A0540.001.3579	22	A1081.006.34357	22
A0474.004	A0540.001.3579	32	A1081.006.34357	32

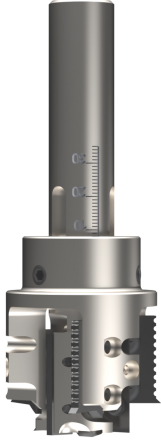

## A0396

gruppo a coltellini per tenonare  
*router cutters set for tenoning*

### DESCRIZIONE / DESCRIPTION

Gruppo a coltellini per tenonare in HW (Hm integrale). Regolazione tenone da 8 a 30 mm.

### DATI TECNICI / TECHNICAL DATA

ART	COD	DRW	D	Z	D2	RI	REG	ROT	S
A0396	001	36231	30	3	53	6	8-30	Dx Rh	20
A0396	002	36358	30	3	53	6	8-30	Sx Lh	20



## RICAMBI / SPARE PARTS

COD.		QTY
A0396.001	A0396.100.98004	1
A0396.002	A0396.101.98005	1



## A0475

Punte a coltelli sagomati z=2 inserto verticale  
*Insert router cutters simple shapes z=2*

### MATERIALE LAVORATO / MATERIALS

legno duro, legno tenero, mdf  
*hHrd wood, hHrd wood, mdf, soft  
 wood*

### IMPIEGO / FUNCTION

centro lavoro cnc  
*cnc router*

### INFO ORDINE / ORDER INFO

Indicare la sagoma del legno richiesta attraverso immagine scansionata, disegno Cad, campione legno. Specificare nell'ordine il materiale dei taglienti Hc o Hs ed indicare il senso di rotazione dell'utensile.

*Indicate the required wood shape through scanned image, Cad drawing, wood sample. Specify in the order the material of the cutting edge Hc or Hs and indicate the rotation direction of the tool.*

### DESCRIZIONE / DESCRIPTION

Punta con 2 coltellini sagomati in HW (HM integrale), di spessore 2 mm. Utensili adatti per eseguire lavori di contornatura su tutti i tipi di legno, truciolare, MDF ecc..

*Router cutters with 2 HW (integral tungsten carbide) profiled knives, 2 mm thickness. Suitable for edging execution on all type of wood, chipboard, MDF etc...*

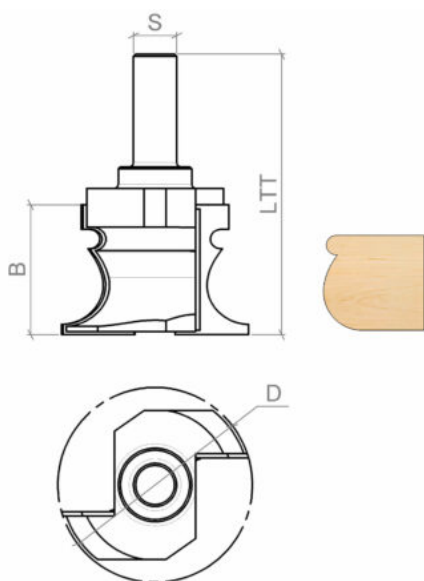

### DATI TECNICI / TECHNICAL DATA

ART	COD	D	B	LTT	Z	ROT	S
A0475	001	40	20	80	2	Dx Rh	20
A0475	002	40	30	90	2	Dx Rh	20
A0475	003	40	40	100	2	Dx Rh	20
A0475	004	40	50	110	2	Dx Rh	20
A0475	005	40	60	120	2	Dx Rh	20
A0475	006	60	20	80	2	Dx Rh	20
A0475	007	60	30	90	2	Dx Rh	20
A0475	008	60	40	100	2	Dx Rh	20
A0475	009	60	50	110	2	Dx Rh	20
A0475	010	60	60	120	2	Dx Rh	20

<b>ART</b>	<b>COD</b>	<b>D</b>	<b>B</b>	<b>LTT</b>	<b>Z</b>	<b>ROT</b>	<b>S</b>
A0475	011	80	20	80	2	Dx Rh	20
A0475	012	80	30	90	2	Dx Rh	20
A0475	013	80	40	100	2	Dx Rh	20
A0475	014	80	50	110	2	Dx Rh	20
A0475	015	80	60	120	2	Dx Rh	20
A0475	016	100	20	80	2	Dx Rh	20
A0475	017	100	30	90	2	Dx Rh	20
A0475	018	100	40	100	2	Dx Rh	20
A0475	019	100	50	110	2	Dx Rh	20
A0475	020	100	60	120	2	Dx Rh	20

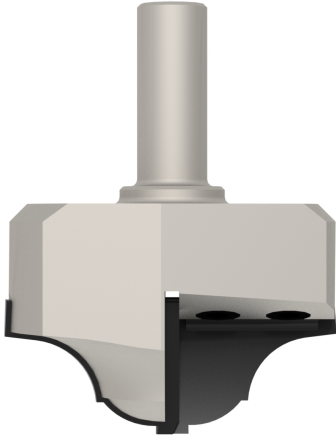

## A0476

Punte a coltelli sagomati z=2 inserto orizzontale  
*Profiled cnc router cutters with horizontal insert position*

### MATERIALE LAVORATO / MATERIALS

legno duro, legno tenero, mdf  
*hHrd wood, hHrd wood, mdf, soft wood*

### IMPIEGO / FUNCTION

centro lavoro cnc  
*cnc router*

### INFO ORDINE / ORDER INFO

Indicare la sagoma del legno richiesta attraverso immagine scansionata, disegno Cad, campione legno. Specificare nell'ordine il materiale dei taglienti Hc o Hs ed indicare il senso di rotazione dell'utensile. Indicare il senso di rotazione dell'utensile.

### DESCRIZIONE / DESCRIPTION

### DATI TECNICI / TECHNICAL DATA

ART	COD	DRW	D	B	LTT	Z	ROT	S
A0476	100	95320	48	30	100	2	Dx Rh	20
A0476	101	95321	58	30	100	2	Dx Rh	20
A0476	102	95322	78	30	100	2	Dx Rh	20
A0476	103	95323	98	30	100	2	Dx Rh	20
A0476	104	95324	118	30	100	2	Dx Rh	20
A0476	105	95325	48	35	105	2	Dx Rh	20
A0476	106	95326	58	35	105	2	Dx Rh	20
A0476	107	95327	78	35	105	2	Dx Rh	20
A0476	108	95328	98	35	105	2	Dx Rh	20
A0476	109	95329	118	35	105	2	Dx Rh	20
A0476	110	95330	48	40	120	2	Dx Rh	20
A0476	111	95331	58	40	120	2	Dx Rh	20
A0476	112	95332	78	40	120	2	Dx Rh	20
A0476	113	95333	98	40	120	2	Dx Rh	20
A0476	114	95334	118	40	120	2	Dx Rh	20

# A0477

Punte a coltellini per giunzioni a 45°  
Router cutters for joint 45°

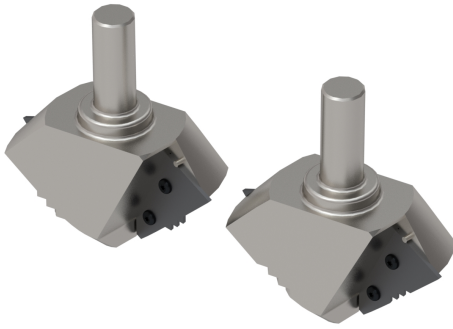

## MATERIALE LAVORATO / MATERIALS

legno duro, legno tenero, mdf  
hHrd wood, hHrd wood, mdf, soft wood

## IMPIEGO / FUNCTION

centro lavoro cnc  
cnc router

## DESCRIZIONE / DESCRIPTION

Punte a coltellini sagomati in HW per esecuzione giunzioni a 45°.

HW profiled router cutters for joint 45°

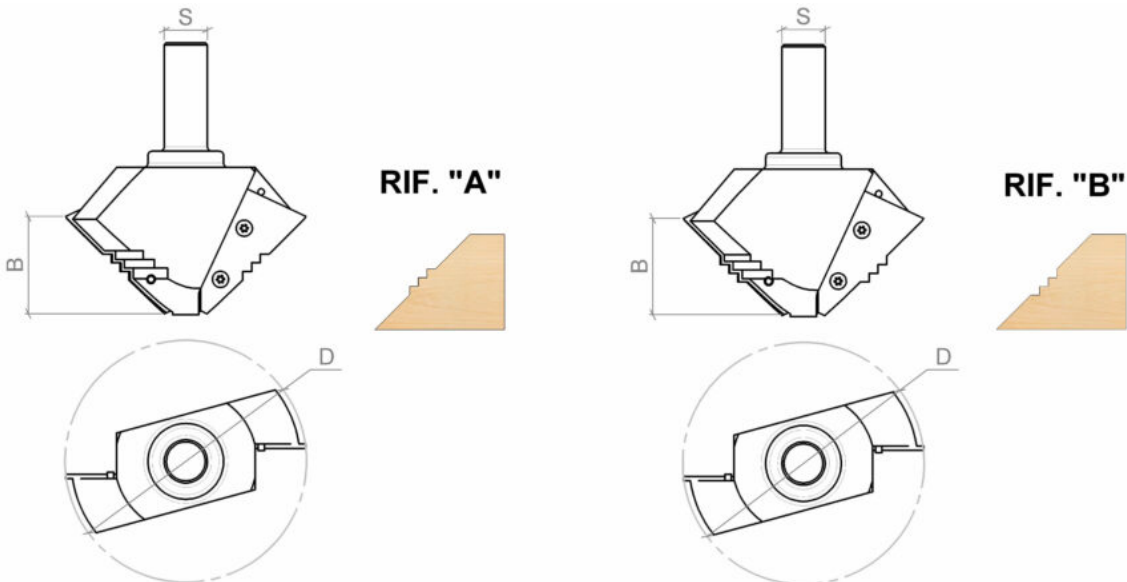

## DATI TECNICI / TECHNICAL DATA

ART	COD	DRW	D	B	LTT	Z	ROT	S	RIF
A0477	001	18672	110	40	125	2	Dx Rh	20	A
A0477	002	18675	110	40	125	2	Dx Rh	20	B

## RICAMBI / SPARE PARTS

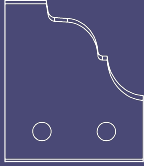
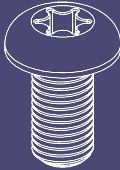
COD.		QTY		QTY
A0477.001	A0560.096.18671	2	A0175.013.15161	4
A0477.002	A0560.096.18674	2	A0175.013.15161	4



## A0482

Punte a coltellini per piattabanda

*Panel rising router cutters*

### MATERIALE LAVORATO / MATERIALS

legno duro, legno tenero, mdf  
*hHrd wood, hHrd wood, mdf, soft  
wood*

### IMPIEGO / FUNCTION

centro lavoro cnc  
*cnc router*

### DESCRIZIONE / DESCRIPTION

Punta a coltellini sagomata per esecuzione profili di bugne.

*HW profiled router cutter for panels of kitchen doors*

### DATI TECNICI / TECHNICAL DATA

ART	COD	DRW	D	B	LTT	Z	ROT	S	RIF
A0482	001	36637	118	25	120	2	Dx Rh	20	A
A0482	002	15556	140	25	120	3	Dx Rh	20	B



## A0484

Punte a coltelli multisagoma jolly  
*Jolly multiprofile router cutters*

### MATERIALE LAVORATO / MATERIALS

legno duro, legno tenero, mdf  
*hHrd wood, hHrd wood, mdf, soft  
 wood*

### IMPIEGO / FUNCTION

centro lavoro cnc  
*cnc router*

### INFO ORDINE / ORDER INFO

Indicare la sagoma del legno richiesta attraverso immagine scansionata, disegno Cad, campione legno. Specificare nell'ordine il materiale dei taglienti Hc o Hs ed indicare il senso di rotazione dell'utensile. Indicare il senso di rotazione dell'utensile.

*Indicate the required wood shape through scanned image, Cad drawing, wood sample. Specify in the order the material of the cutting edge Hc or Hs and indicate the rotation direction of the tool*

### DESCRIZIONE / DESCRIPTION

Punte sagomate con corpo universale Z=2 con coltellini sagomati in HW (Hm integrale), di spessore 2 mm o 3 mm. Con lo stesso corpo è possibile realizzare vari profili su disegno del cliente. Adatto a tutti i tipi di legno, truciolare, e MDF.

*Router cutters with universal body Z=2 with HW profiled knives, 2 mm or 3 mm thickness. With the same body it's possible to realize various profiles. Suitable for all types of wood, chipboard and MDF.*

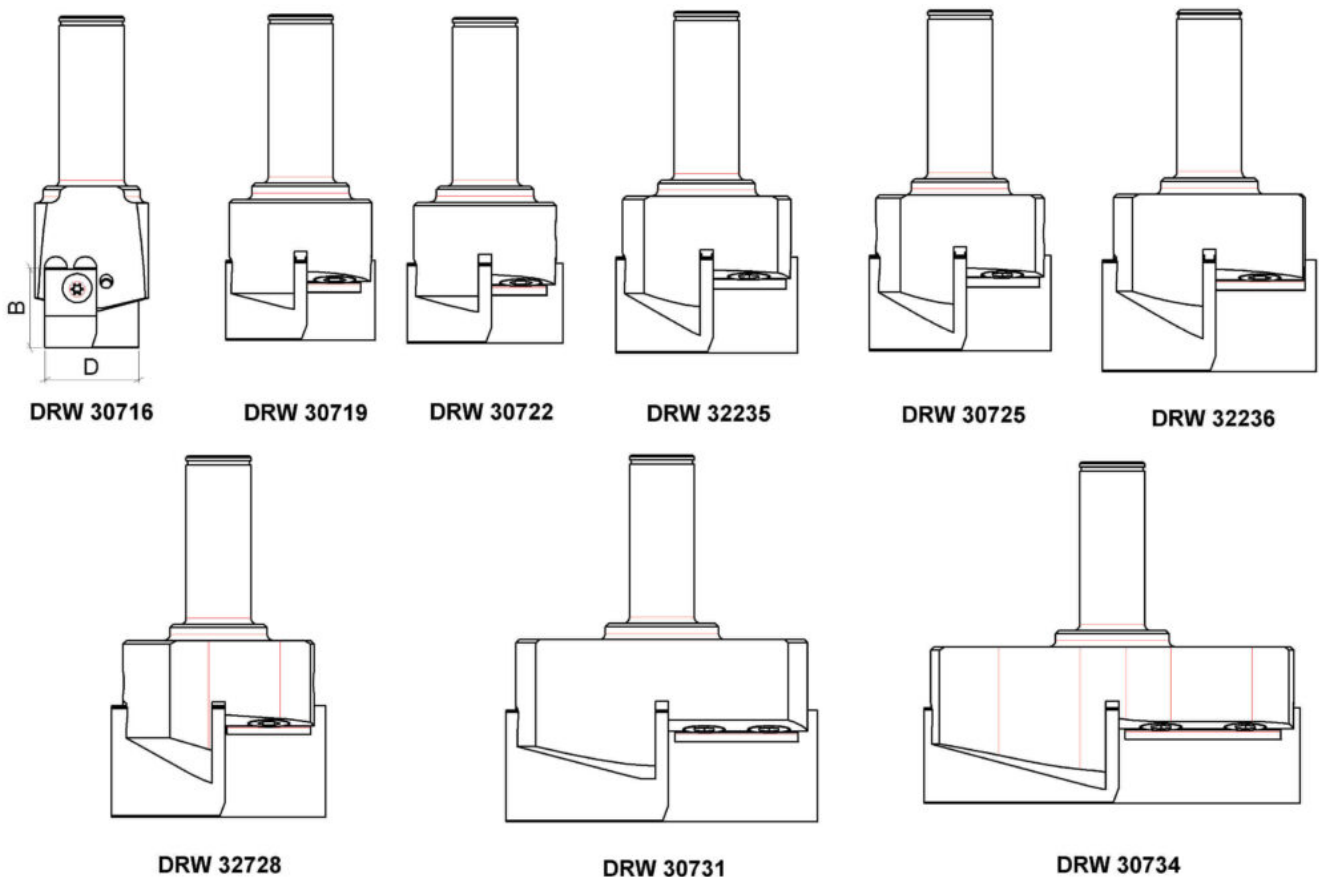

### DATI TECNICI / TECHNICAL DATA

ART	COD	DRW	D	B	Z	ROT	S	GT
-----	-----	-----	---	---	---	-----	---	----



A0484	101	30716	35	25	2	Dx Rh	20	<i>Assiale / Axial</i>
A0484	102	30719	46	25	2	Dx Rh	20	<i>Assiale / Axial</i>
A0484	104	32235	56	30	2	Dx Rh	20	<i>Assiale / Axial</i>
A0484	106	32236	66	35	2	Dx Rh	20	<i>Assiale / Axial</i>
A0484	108	30731	96	35	2	Dx Rh	20	<i>Assiale / Axial</i>
A0484	109	30734	116	30	2	Dx Rh	20	<i>Assiale / Axial</i>

## RICAMBI / SPARE PARTS

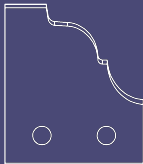
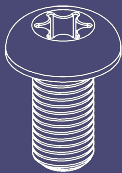
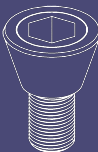
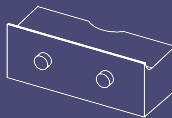
COD.		QTY		QTY		QTY		QTY
A0484.101	A0559.005.30715	2	A1075.015.3452	2				
A0484.102	A0559.011.2633	2			A1078.015.6439	2	A1057.022.15751	2
A0484.104	A0559.018.2502	2			A1078.015.6439	2	A1057.023.15752	2
A0484.106	A0559.024.2509	2			A1078.015.6439	2	A1057.024.15598	2
A0484.108	A0559.035.2525	2			A1078.015.6439	2	A1057.025.16569	2
A0484.109	A0559.039.2532	2			A1078.015.6439	2	A1057.026.15604	2



## A0485

Punte a coltellini multisagoma  
*Multiprofile insert router cutters*

### MATERIALE LAVORATO / MATERIALS

legno duro, legno tenero, mdf  
*hHrd wood, hHrd wood, mdf, soft  
wood*

### IMPIEGO / FUNCTION

centro lavoro cnc  
*cnc router*

### DESCRIZIONE / DESCRIPTION

Punta con angolo assiale, Z=1/Z=2 coltellini sagomati in HW (Hm integrale), spessore 1,5-2 mm. La punta è fornita con un profilo a scelta. Particolarmente adatto per lavorazioni interne decorative su tutti i tipi di legno, truciolare e MDF.

*Router cutter with Z=1/Z=2 HW (integral tungsten carbide) profiled inserts, 1,5-2 mm thickness. The insert router bit is supplied with one profile at choice. Particularly indicated for internal decoration working on all type of wood, chipboard and MDF.*

### DATI TECNICI / TECHNICAL DATA

ART	COD	DRW	D	B	Z	GT
A0485	008	96048	24	40	1	Dritta / Straight



## A0486

Punte a coltellini per smussi e incisioni  
*Bevelling and carving insert router cutters*

### MATERIALE LAVORATO / MATERIALS

legno duro, legno tenero, mdf  
*hHrd wood, hHrd wood, mdf, soft  
 wood*

### IMPIEGO / FUNCTION

centro lavoro cnc  
*cnc router*

### DESCRIZIONE / DESCRIPTION

Punte a coltellini per smussare e/o incidere su pannelli truciolari e MDF

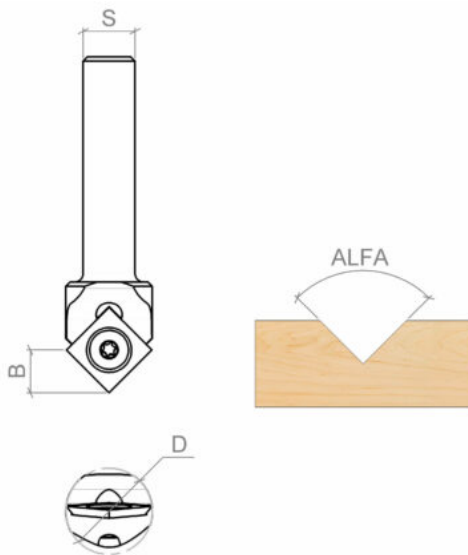

*Bevelling and carving router cutters for chipboard panels and MDF*



### DATI TECNICI / TECHNICAL DATA

ART	COD	DRW	D	B	Z	ROT	S	RIF	ALFA
A0486	001	28656	22	19	1	Dx Rh	12	A	60
A0486	002	20914	20	10	1	Dx Rh	12	B	90

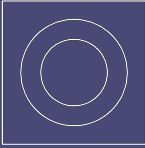
## RICAMBI / SPARE PARTS

COD.		QTY		QTY
A0486.001	A0542.001.13159	1	A1081.005.34356	1
A0486.002	A0540.001.3579	1	A1081.005.34356	1

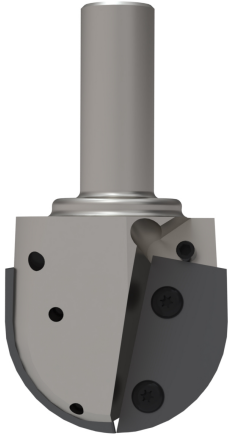

## A0492

Punta portacoltelli sagomata semisferica  
*Bull nose insert router bits*

### DESCRIZIONE / DESCRIPTION

Punta a coltelli per lavorazioni di svuotamento e realizzazione di superfici curve.

*Knife tip for hollowing out and creating curved surfaces.*

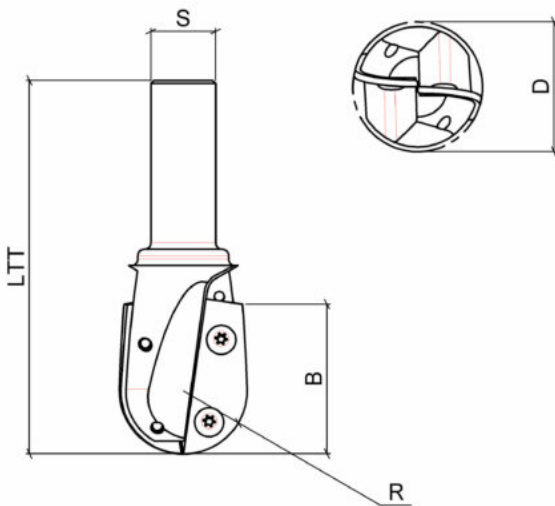

### DATI TECNICI / TECHNICAL DATA

ART	COD	DRW	D	B	LTT	Z	ROT	S	R	GT
A0492	001	21059	30	47	113	2	Dx Rh	20	15	sagomata /
A0492	003	21055	40	46	115	2	Dx Rh	20	20	sagomata /
A0492	004	20882	60	44	115	2	Dx Rh	20	30	sagomata /
A0492	005	25556	70	48	119	2	Dx Rh	20	35	sagomata /
A0492	006	15823	100	50	115	2	Dx Rh	20	50	sagomata /

## RICAMBI / SPARE PARTS

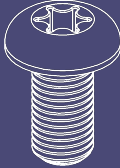
COD.		QTY		QTY
A0492.001	A0560.181.21058	2	A1075.015.3452	4
A0492.003	A0560.181.21054	2	A1075.015.3452	4
A0492.004	A0560.076.20881	2	A1075.015.3452	4
A0492.005	A0560.096.25555	2	A1075.015.3452	4
A0492.006	A0560.116.15822	2	A1075.015.3452	4

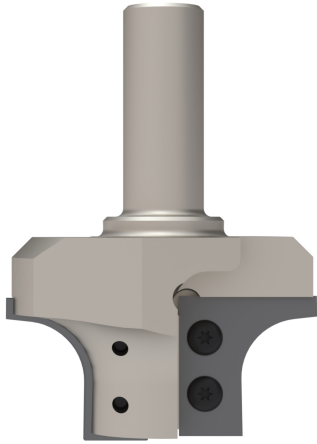

## A0491

Punta sagomata per squadratura e contornatura a 1/4 di tondo concavo

*Quarter circle squaring and contouring insert router bits*





### DESCRIZIONE / DESCRIPTION

### DATI TECNICI / TECHNICAL DATA

ART	COD	DRW	D	B	LTT	Z	D2	ROT	S	RIF	R	GT
A0491	001	47470	60	30	102	2	40	Dx Rh	20	R3-5-6-7.5	3	sagomata /
A0491	002	47473	70	30	102	2	40	Dx Rh	20	R10-12,5	10	sagomata /
A0491	003	47476	80	30	102	2	40	Dx Rh	20	R15-17,5	15	sagomata /
A0491	004	47479	60	35	100	2	40	Dx Rh	20	R3-5-6-7.5	3	sagomata /
A0491	005	47482	70	35	100	2	40	Dx Rh	20	R10-12,5	10	sagomata /
A0491	006	47485	80	35	100	2	40	Dx Rh	20	R15-17,5	15	sagomata /



## RICAMBI / SPARE PARTS

COD.		QTY		QTY		QTY		QTY
A0491.001	A0560.041.51655	2	A0560.041.51656	2	A0560.041.51657	2	A0560.041.51658	2
A0491.002	A0560.046.51659	2	A0560.046.51660	2				
A0491.003	A0560.051.51661	2	A0560.051.51662	2				
A0491.004	A0560.041.51663	2	A0560.041.51664	2	A0560.041.51665	2	A0560.041.51666	2
A0491.005	A0560.161.51667	2	A0560.161.51668	2				
A0491.006	A0560.166.51669	2	A0560.166.51670	2				

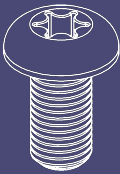
COD.		QTY
A0491.001	A1075.015.3472	4
A0491.002	A1075.015.3472	4
A0491.003	A1075.015.3472	4
A0491.004	A1075.015.3472	4
A0491.005	A1075.015.3472	4
A0491.006	A1075.015.3472	4

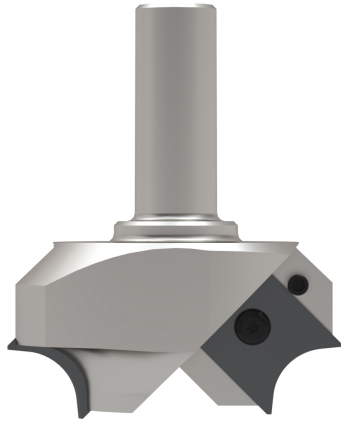

## A0481





Punte a coltelli per quarti di tondo concavo  
*Quarter circle insert router bits*

### DESCRIZIONE / DESCRIPTION

### DATI TECNICI / TECHNICAL DATA

ART	COD	DRW	D	B	LTT	Z	D2	ROT	S	RIF	R	GT
A0481	001	47510	72	15	85	2	50	Dx Rh	20	R 3-5-6-7,5	3	Dritta / Straight
A0481	002	47513	85	25	95	2	50	Dx Rh	20	R 10-12.5-15	10	Dritta / Straight
A0481	003	47516	100	35	95	2	50	Dx Rh	20	R 17.5 - 20	17.5	Dritta / Straight
A0481	004	47519	112	50	115	2	50	Dx Rh	20	R25-30	25	Dritta / Straight

**RICAMBI / SPARE PARTS**

COD.		QTY		QTY		QTY		QTY
A0481.001	A0560.001.51675	2	A0560.001.51676	2	A0560.001.51677	2	A0560.001.51678	2
A0481.002	A0560.026.51679	2	A0560.026.51680	2	A0560.026.51681	2		
A0481.003	A0560.156.51682	2	A0560.156.51683	2				
A0481.004	A0560.081.51684	2	A0560.081.51685	2				

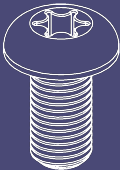
COD.		QTY
A0481.001	A1075.015.3472	2
A0481.002	A1075.015.3472	2
A0481.003	A1075.015.3472	4
A0481.004	A1075.015.3472	4

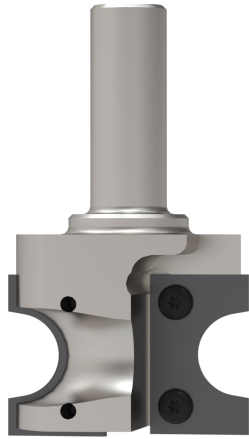

## A0488

Punte a coltelli per mezzo tondo  
*Half circle insert router bits*

### DESCRIZIONE / DESCRIPTION

### DATI TECNICI / TECHNICAL DATA

ART	COD	DRW	D	B	LTT	Z	D2	ROT	S	RIF	R	GT
A0488	001	47534	60	30	95	2	30	Dx Rh	20	R5 - 7.5	5	sagomata /
A0488	002	47537	70	35	105	2	30	Dx Rh	20	R10-12.5	10	sagomata /
A0488	003	47540	100	60	125	2	50	Dx Rh	20	R15-17.5- 20	15	sagomata /
A0488	004	47543	115	80	145	2	40	Dx Rh	20	R22.5-25- 30	22.5	sagomata /

## RICAMBI / SPARE PARTS

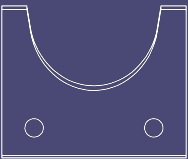
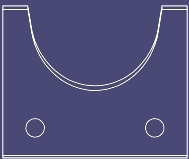
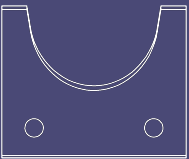
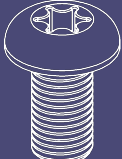
COD.		QTY		QTY		QTY		QTY
A0488.001	A0560.041.51697	2	A0560.041.51698	2			A1075.015.3472	4
A0488.002	A0560.061.51699	2	A0560.061.51700	2			A1075.015.3472	4
A0488.003	A0560.106.51701	2	A0560.106.51702	2	A0560.106.51703	2	A1075.015.3472	4
A0488.004	A0560.999.51704	2	A0560.999.51705	2	A0560.999.51706	2	A1075.015.3472	4



## A0493

Punte a coltelli per spianare  
*Planing insert router bits*

### MATERIALE LAVORATO / MATERIALS

legno duro, mdf  
*hHrd wood, hHrd wood, mdf*

### IMPIEGO / FUNCTION

centro lavoro cnc  
*cnc router*

### DESCRIZIONE / DESCRIPTION

Punta a inserti per la lavorazione di spianatura su pannello. Particolarmente indicata per il livellamento del piano martire nelle lavorazioni di nesting su macchine a controllo cnc.

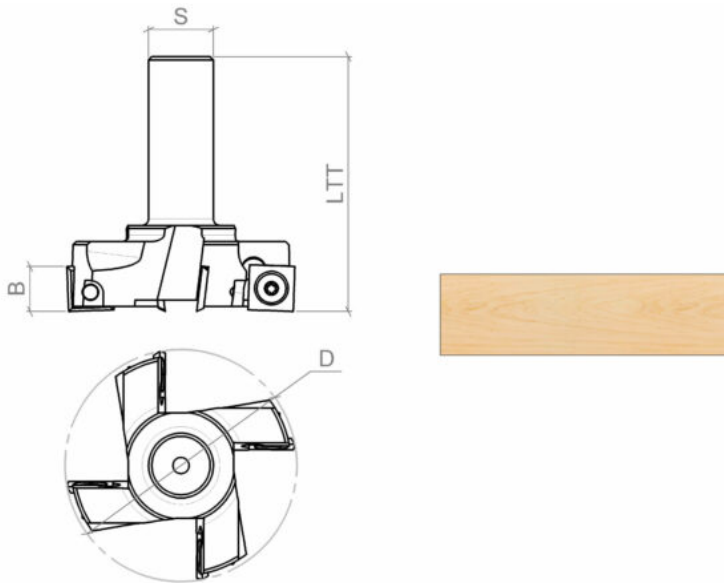

*Insert tool for flattening work on panels. Particularly suitable for leveling the mating surface in nesting operations on CNC controlled machines.*



### DATI TECNICI / TECHNICAL DATA

ART	COD	DRW	D	B	LTT	Z	ROT	S	GT
A0493	001	17046	50	14	85	3	Dx Rh	20	Assiale / Axial
A0493	002	85635	70	14	85	4	Dx Rh	20	Assiale / Axial
A0493	003	82553	80	14	85	4	Dx Rh	20	Assiale / Axial
A0493	004	33762	100	14	85	5	Dx Rh	20	Assiale / Axial
A0493	005	24878	120	14	85	5	Dx Rh	20	Assiale / Axial
A0493	006	33243	150	14	85	5	Dx Rh	25	Assiale / Axial

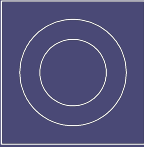
## RICAMBI / SPARE PARTS

COD.		QTY	
A0493.001	A0540.001.3579	3	A1081.006.34357
A0493.002	A0540.001.3579	4	A1081.006.34357
A0493.003	A0540.001.3579	4	A1081.006.34357
A0493.004	A0540.001.3579	5	A1081.006.34357
A0493.005	A0540.001.3579	5	A1081.006.34357
A0493.006	A0540.001.3579	5	A1081.006.34357



## A2149

Punte per contornatura registrabile  
*Adjustabel contouring router tool*

### DESCRIZIONE / DESCRIPTION

### DATI TECNICI / TECHNICAL DATA

ART	COD	DRW	D	B	Z	SG45	ROT	S
A2149	001	86098	80	50	2	4	Dx Rh	20



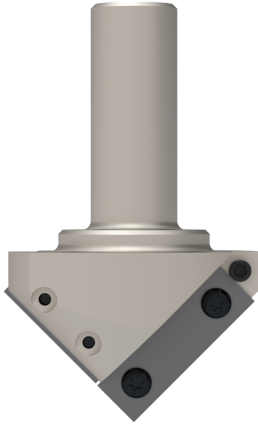

## A0494

Punte a coltelli per canali a v  
*V groove insert router bits*

### MATERIALE LAVORATO / MATERIALS

mdf  
mdf

### IMPIEGO / FUNCTION

centro lavoro cnc  
cnc router

### DESCRIZIONE / DESCRIPTION

Punta a coltelli per esecuzione canali a V su pannelli in mdf o legno naturale. Le diverse inclinazioni degli inserti consentono l'impiego nella produzione di scatolati di varie forme.

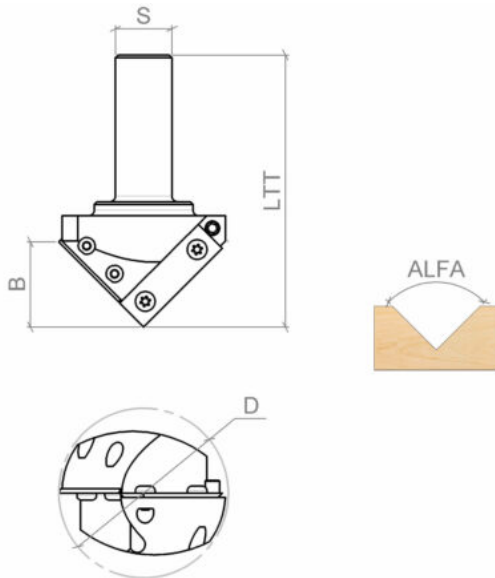

*Insert tool for making V-shaped channels on mdf or natural wood panels. The different inclinations of the inserts allow their use in the production of boxes of various shapes.*



### DATI TECNICI / TECHNICAL DATA

ART	COD	DRW	D	B	LTT	Z	ROT	S	ALFA	GT
A0494	001	82827	57.5	45	118	2	Dx Rh	20	60	Dritta / Straight
A0494	002	84997	60	28	97	2	Dx Rh	20	90	Dritta / Straight
A0494	003	20909	75	21	97	2	Dx Rh	20	120	Assiale / Axial
A0494	004	25529	84	18	97	2	Dx Rh	20	135	Assiale / Axial
A0494	005	19608	100	16	97	2	Dx Rh	20	150	Assiale / Axial
A0494	006	86523	130	12	88	2	Dx Rh	20	165	Assiale / Axial

## RICAMBI / SPARE PARTS

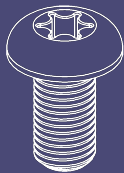
COD.		QTY		QTY		QTY
A0494.001	A0550.026.25114	2			A1075.011.5437	4
A0494.002	A0520.024.3362	1	A0520.008.3348	1	A1075.011.5437	4
A0494.003	A0550.026.19760	2			A1075.011.5437	4
A0494.004	A0550.026.25558	2			A1075.011.5437	4
A0494.005	A0550.012.3352	2			A1075.011.5437	4
A0494.006	A0520.029.3365	2			A1075.011.5437	4

## A0490

Set completo per esecuzione antina in legno massello

*Insert router cutter set for solid wood door exec.*

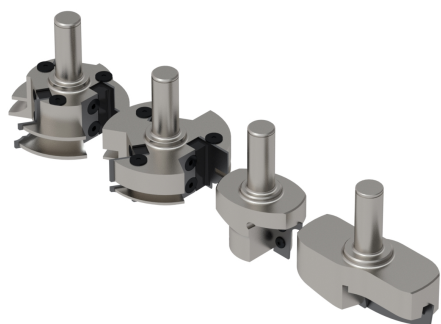

### IMPIEGO / FUNCTION

centro lavoro cnc  
cnc router

### DESCRIZIONE / DESCRIPTION

set di utensili per l'esecuzione dell'antina in legno massello, con coltellini HW(Hm integrale). Possibilità di variare tipo di sagoma e tipo di attacco a preventivo. Ogni singola punta pu  essere ordinata separatamente. Adatto per tutti i tipi di legni naturali.

*insert cutter set for solid wood door execution, with HW(integral tungsten carbide) inserts. Possibility to change profile and shank type to be quoted. Every single cutter can be ordered separately. Suitable for all kind of natural woods*

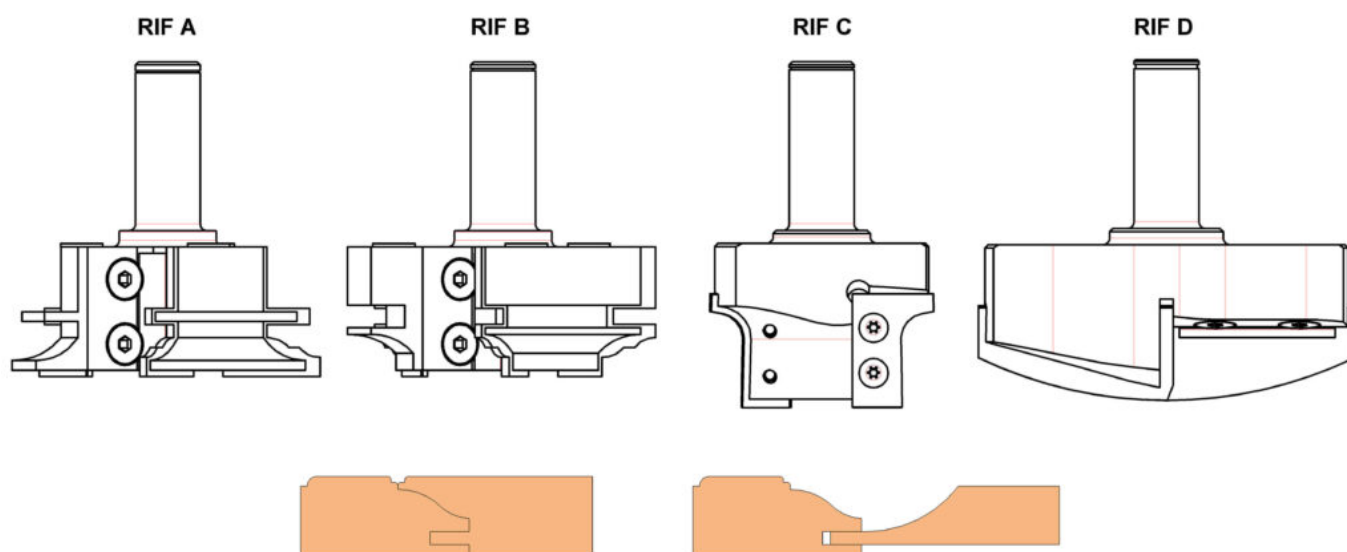

### DATI TECNICI / TECHNICAL DATA

ART	COD	DRW	D	B	Z	ROT	S	RIF
A0490	040	11663	100	40	3	Dx Rh	20	A
A0490	041	11666	100	40	3	Dx Rh	20	B
A0490	052	52502	70	35	2	Dx Rh	20	C
A0490	053	80700	120	30	2	Dx Rh	20	D



## A2124

Punte per esecuzione sede maniglia  
Handle seat router tools

### MATERIALE LAVORATO / MATERIALS

mdf, truciolare  
chipboard, mdf

### IMPIEGO / FUNCTION

centro lavoro cnc  
cnc router

### INFO ORDINE / ORDER INFO

Utensile equipaggiato con coltello Rif.A Drw 48260. Altri coltelli a richiesta.

Tool equipped with knife Rif.A Drw 48260. Other knives optional.

### DESCRIZIONE / DESCRIPTION

Punte per eseguire la sede della maniglia su ante di cucine e mobili. Sostituendo i coltelli in dotazione con quelli opzionali, ordinabili a parte, è possibile ottenere sagome diverse e spessori differenti.

Tool for making the seat of the handle on kitchen and furniture doors. By replacing the supplied knives with the optional ones, which can be ordered separately, it is possible to obtain different shapes and different thicknesses.

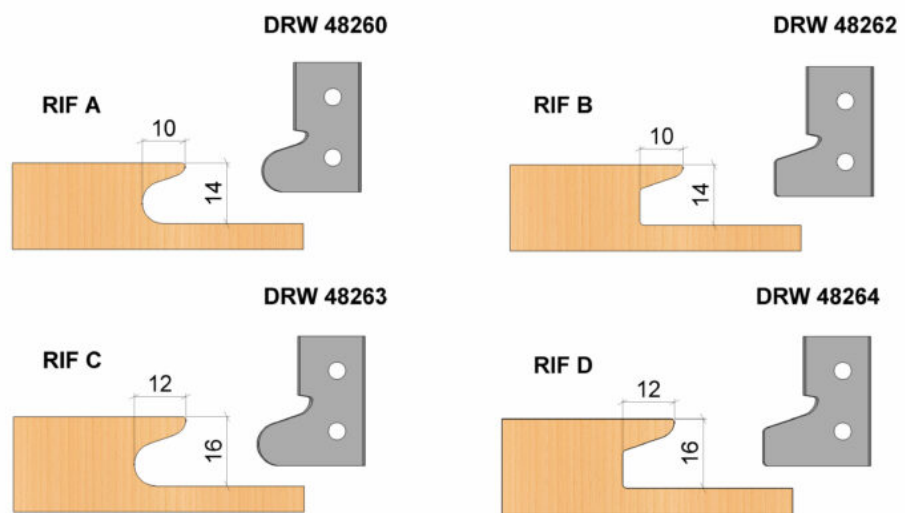
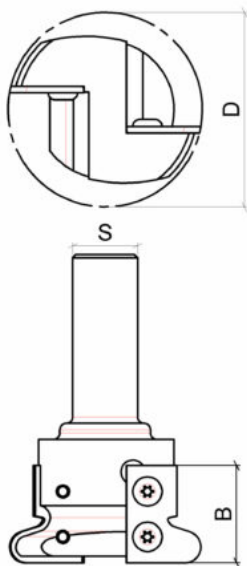

### DATI TECNICI / TECHNICAL DATA

ART	COD	DRW	D	B	Z	D2	REG	ROT	S
A2124	001	48261	60	30	2	40	14-16	Dx Rh	20

**RICAMBI / SPARE PARTS**

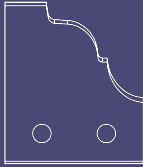
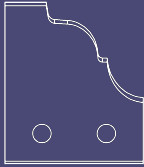
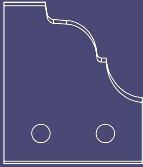
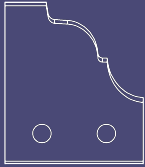
COD.		QTY		QTY		QTY		QTY
A2124.001	A0560.041.48260	2	A0560.041.48262	2	A0560.041.48263	2	A0560.041.48264	2

COD.		QTY
A2124.001	A1075.015.3452	4



## A2128

Punte portacoltelli per raggiare spigoli  
*Router insert tools for rounding edges*

### IMPIEGO / FUNCTION

centro lavoro cnc  
*cnc router*

### INFO ORDINE / ORDER INFO

Utensile fornito con coltelli raggio 3 mm.  
*Tool supplied with 3 mm radius knives.*

### DESCRIZIONE / DESCRIPTION

Punta multisagoma a coltelli per raggiare o smussare spigoli, sia sul lato superiore che su quello inferiore del pannello. Cambiando gli inserti si possono realizzare smussi e raggiature di dimensioni differenti.

*Multi-shape insert tool for rounding or chamfering edges, both on the upper and lower sides of the panel. By changing the inserts it is possible to create chamfers and radii of different dimensions*

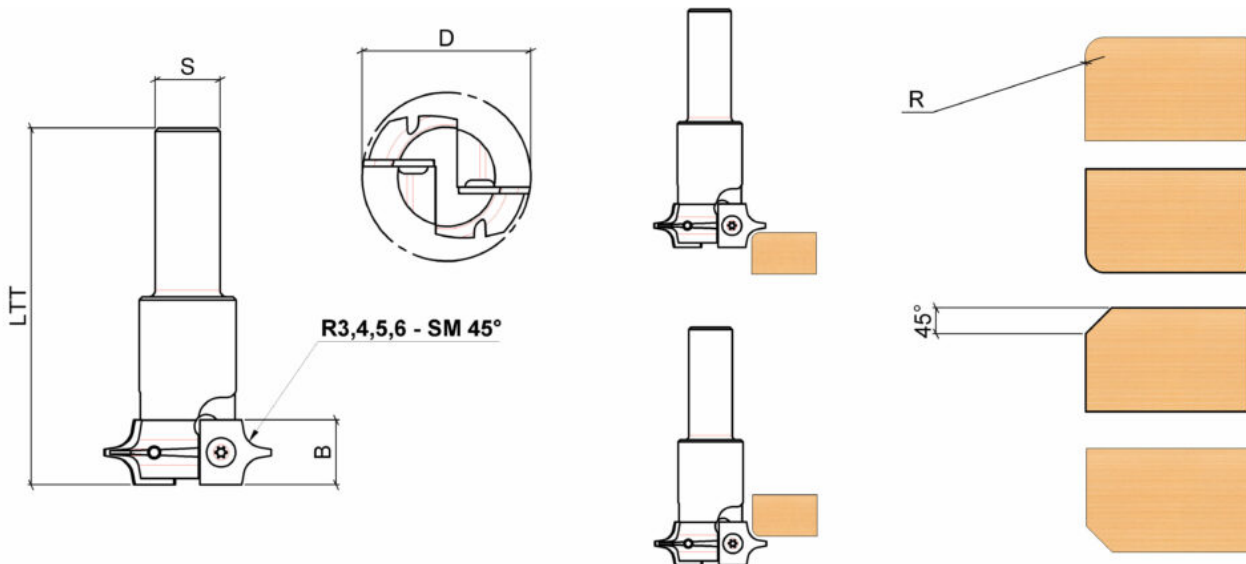

### DATI TECNICI / TECHNICAL DATA

ART	COD	DRW	D	B	LTT	Z	ROT	S	R
A2128	001	85601	52	20	110	2	Dx Rh	20	3

## RICAMBI / SPARE PARTS

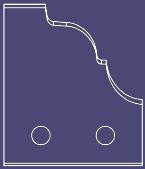
COD.		QTY		QTY		QTY		QTY
A2128.001	A0560.011.87439	2	A0560.011.95397	2	A0560.011.95398	2	A0560.011.85757	2

COD.		QTY		QTY
A2128.001	A0560.011.95399	2	A1075.015.3452	2

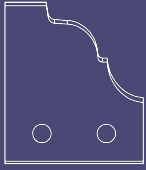
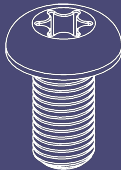

## A2141

Punta portacoltelli a palla  
*router cutter ball shape*

### DESCRIZIONE / DESCRIPTION

Punte ad inserti per la lavorazione di stampi e superfici complesse anche in posizione sottosquadra

*Insert router tool for mould process even on undercut position*

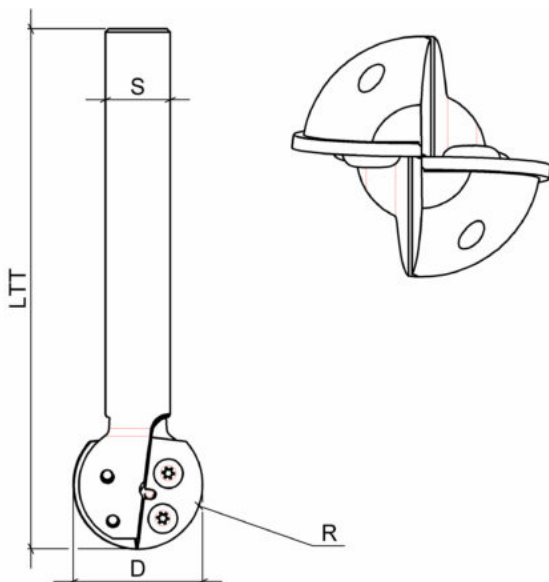

### DATI TECNICI / TECHNICAL DATA

ART	COD	DRW	D	B	LTT	Z	ROT	S	R
A2141	001	95387	36	35	160	2	Dx Rh	20	18
A2141	002	93674	40	35	160	2	Dx Rh	20	20

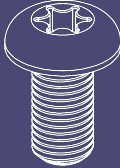

## RICAMBI / SPARE PARTS

COD.		QTY		QTY
A2141.001	A0560.999.95386	2	A1075,015.3452	4
A2141.002	A0560.999.93673	2	A1075,015.3452	4

## A2137

Gruppo lama con attacco cilindrico  
Saw blade set with cylindrical shank

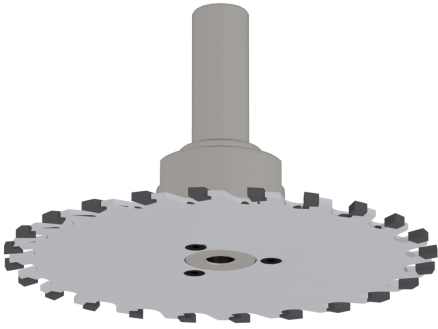

### IMPIEGO / FUNCTION

Centro di lavoro cnc  
cnc router

### DESCRIZIONE / DESCRIPTION

Lama circolare montata su alberino adattatore con attacco cilindrico. Ideale per sezionature e canali su macchine cnc. Al centro dell'alberino è presente un foro diametro 10 mm h7 che insieme a due viti senza testa permette l'eventuale alloggiamento di una punta o una fresa con attacco 10 mm dotato di spiano.

*Circular blade mounted on adapter shaft with cylindrical attachment. Ideal for sizing and channels on cnc machines. At the center of the shaft there is a hole with a diameter of 10 mm h7 which, together with two headless screws, allows the possible housing of a bit or a milling cutter with a 10 mm attachment equipped with a flat.*

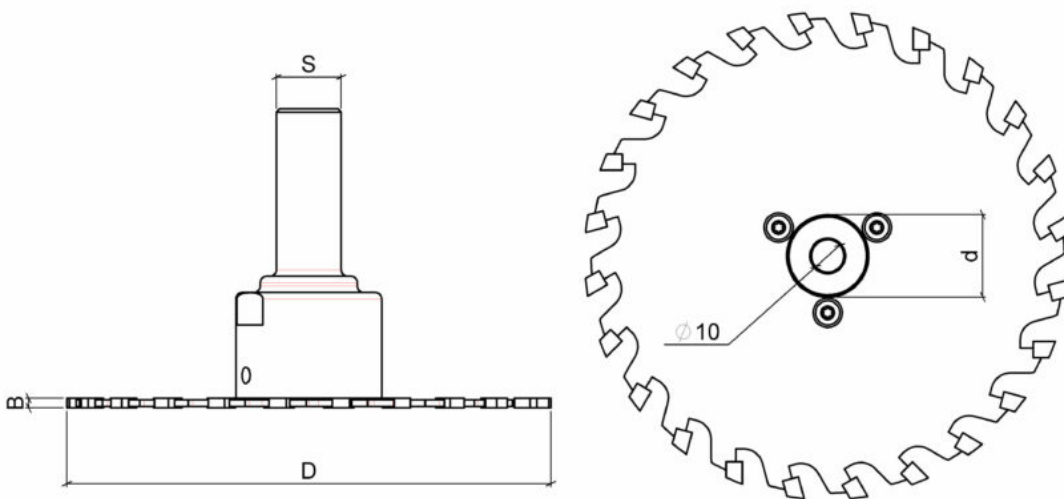

### DATI TECNICI / TECHNICAL DATA

ART	COD	DRW	D	B	d	D2	ROT	S	GT
A2137	001	25210	150	3.2	25	25	Dx - Rh	20	Dente alternato / Alternated teeth
A2137	002	33068	160	3.2	25	25	Dx - Rh	20	Dente alternato / Alternated teeth
A2137	003	95734	200	3.2	25	25	Dx - Rh	20	Dente alternato / Alternated teeth
A2137	004	30901	400	4	30	30	Dx - Rh	25	Dente alternato / Alternated teeth

# A0495

Set completo per esecuzione antina in m.d.f.  
*Insert router cutter set for m.d.f. door exec.*

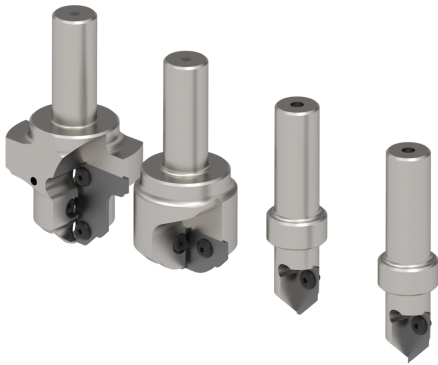

**MATERIALE LAVORATO /  
 MATERIALS**  
 mdf  
 mdf

**IMPIEGO / FUNCTION**  
 centro lavoro cnc  
 cnc router

## DESCRIZIONE / DESCRIPTION

Set di utensili per l'esecuzione di antine in M.D.F. con coltellini HW(Hm integrale). Ogni singola punta può essere ordinata separatamente.

*Insert cutter set for M.D.F. door execution, with HW(integral tungsten carbide) inserts. Every single cutter can be ordered separately.*

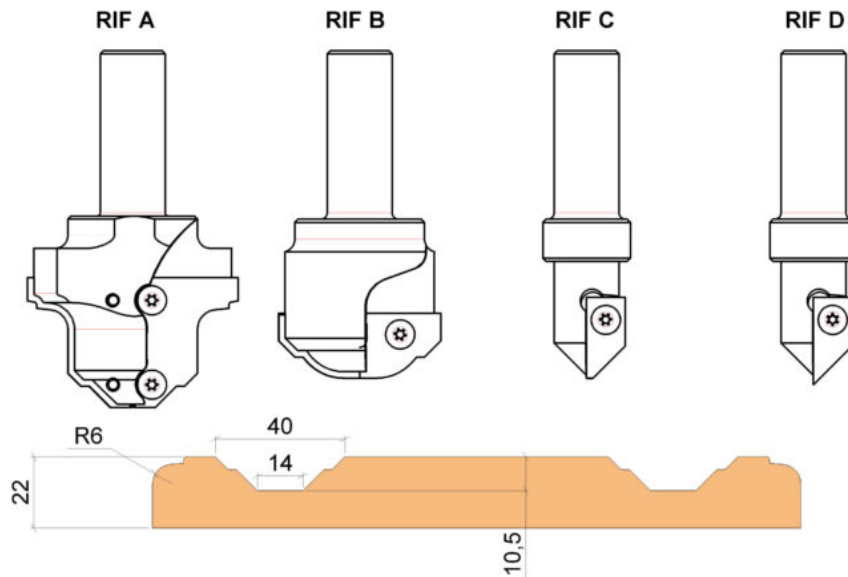

## DATI TECNICI / TECHNICAL DATA

ART	COD	DRW	D	B	LTT	Z	ROT	S	RIF
A0495	001	5435	65	40	110	2	Dx Rh	20	A
A0495	002	51824	50	25	110	2	Dx Rh	20	B
A0495	003	5451	24	40	95	1	Dx Rh	20	C
A0495	004	5453	24	40	95	1	Dx Rh	20	D
A0495	100	94377	0	0	0	0	Dx Rh	0	Gruppo completo / Complete set

## RICAMBI / SPARE PARTS

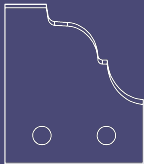
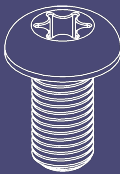
COD.		QTY		QTY
A0495.001	A0560.066.5434	2	A1075.015.3452	4
A0495.002	A0560.141.51823	2	A1075.015.3452	4
A0495.003	A0550.021.5450	1	A1075.014.38251	1
A0495.004	A0550.021.5452	1	A1075.014.38251	1
A0495.100				



## A2134

Kit completo per lavorazione sedie in legno su macchina cnc

*Complete kit for wooden chairs processing on cnc machine*

### IMPIEGO / FUNCTION

Centro di lavoro cnc  
cnc router

### DESCRIZIONE / DESCRIPTION

Kit completo

*Complete Kit*

QTT.	ART.CODE.DRW	DESCRIZIONE
1	A0393.005.52421	GRUPPO A COLTELLINI PER STONDANTE DOPPIA / CENTRO DI LAVORO Z=3/3 / HW D/D1=80/60 B/B1=50/30 d=25 Ri=6 DX SU ALBERINO D=20X50 REG.10-35
1	A0471.001.15757	PUNTA A COLTELLI MULTITAGLIENTI PER CONTORNARE D=80 B=85 CORPO IN ALLUMINIO CON COLTELLI DI 24,7X12X1,5 MONTATA SU ALBERINO D=20X50
1	A2137.001.25210	GRUPPO LAMA CON ATTACCO CILINDRICO D=150 B=3 Z=24 DENTE ALTERNATO ATTACCO D=20X50
1	A0428.010.28167	PUNTA ELICOIDALE IN HW (HM INTEGRALE) Z=3 CON ROMPIRUCIOLO PER SGROSSATURA PER LEGNO D=16 B=42 LTT=100 DX POS
1	A0428.006.28163	PUNTA ELICOIDALE IN HW (HM INTEGRALE) Z=3 CON ROMPIRUCIOLO PER SGROSSATURA PER LEGNO D=12 B=42 LTT=100 DX POS
1	A0428.004.28161	PUNTA ELICOIDALE IN HW (HM INTEGRALE) Z=3 CON ROMPIRUCIOLO PER SGROSSATURA PER LEGNO D10 B42 LTT100 RH POS
1	A0425.010.28151	PUNTA ELICOIDALE IN HW (HM INTEGRALE) Z=3 PER LEGNO D=16 B=42 LTT=100 DX POS
1	A2007.004.36782	PUNTA ELICOIDALE IN HW (HM INTEGRALE) Z=2 CON TESTA SFERICA R=3 PER PER LEGNO D=6 B=17 LTT=50 R=3 DX POS
2	A1030.032.81894	PINZA ELASTICA ER32 D20/19
1	A1030.028.81890	PINZA ELASTICA ER32 D16/15
1	A1030.024.81886	PINZA ELASTICA ER32 D12/11
1	A1030.022.81884	PINZA ELASTICA ER32 D10/9
1	A1030.018.81880	PINZA ELASTICA ER32 D6/5
1	A1090.001.82089	CHIAVE A BRUGOLA 2
1	A1091.002.82098	CHIAVE A BRUGOLA FORMA A T 3
1	A1094.010.82110	CHIAVE TORX A CACCIAVITE T9
1	A1094.011.82111	CHIAVE TORX A CACCIAVITE T15
1	A1094.012.90983	CHIAVE TORX A CACCIAVITE T20

QTT.	ART.CODE.DRW	DESCRIPTION
1	A0393.005.52421	INSERT CUTTER SET Z=3/3 / HW D/D1=80/60 B/B1=50/30 d=25 Ri=6 RH ON TOOL HOLDER D=20X50 REG.10-35
1	A0471.001.15757	INSERT MULTICUT ROUTER CUTTER - 24,7x12x1,5 knives D=80 B=85 Z6+3 WITH ALUMINIUM BODY - ON TOOL HOLDER D=20X50
1	A2137.001.25210	SAW BLADE SET WITH CILINDRICAL D=150 B=3 Z=24 ALTERNATED TEETH SHANK D=20X50
1	A0428.010.28167	HW (INTEGRAL TUNGSTEN CARBIDE) HELICAL ROUTER BIT Z=3 WITH CHIP-BREAKER D=16 B=42 LTT=100 RH POS FOR WOOD
1	A0428.006.28163	HW (INTEGRAL TUNGSTEN CARBIDE) HELICAL ROUTER BIT Z=3 WITH CHIP-BREAKER D=12 B=42 LTT=100 RH POS FOR WOOD
1	A0428.004.28161	HW (INTEGRAL TUNGSTEN CARBIDE) HELICAL ROUTER BIT Z=3 WITH CHIP-BREAKER D=10 B=42 LTT=100 RH POS FOR WOOD
1	A0425.010.28151	HW (INTEGRAL TUNGSTEN CARBIDE) HELICAL ROUTER BIT Z=3 D=16 B=42 LTT=100 RH POS FOR WOOD
1	A2007.004.36782	HW (INTEGRAL TUNGSTEN CARBIDE) HELICAL ROUTER BIT Z=2 SPHERICAL R=3 D=6 B=17 LTT=50 RH POS FOR WOOD
2	A1030.032.81894	ER COLLECT ER32 D20/19
1	A1030.028.81890	ER COLLECT ER32 D16/15
1	A1030.024.81886	ER COLLECT ER32 D12/11
1	A1030.022.81884	ER COLLECT ER32 D10/9
1	A1030.018.81880	ER COLLECT ER32 D6/5
1	A1090.001.82089	ALLEN KEY 2
1	A1091.002.82098	ALLEN KEY - T 3
1	A1094.010.82110	TORX KEY SCREWDRIVER T9
1	A1094.011.82111	TORX KEY SCREWDRIVER T15
1	A1094.012.90983	TORX KEY SCREWDRIVER T20

### DATI TECNICI / TECHNICAL DATA

ART	COD	DRW
A2134	001	95690



## A2140

Kit completo startup per macchina cnc  
*Complete kit startup for cnc machine*

### **IMPIEGO / FUNCTION**

Centro di lavoro cnc  
*cnc router*

### **DESCRIZIONE / DESCRIPTION**

QTT.	ART.CODE.DRW	DESCRIZIONE
1	A0428.011.28168	PUNTE ELICOIDALI IN HM INTEGRALE D16X52X100 Z3+R DX POS
1	A2108.007.89550	PUNTA IN DIAMANTE USA E GETTA D16X27 Z3+1 ATTACCO 20X50 DX
1	A0485.008.96048	PUNTA MULTIPROFILI A COLTELLI IN HM Z=1 D=24 B=25 ATTACCO=20 DISEGNO 96048 DX - CON 3 SET DI COLTELLI SAGOMATI codice 96058 - 96059 - 96060
1	A0493.002.85635	PUNTA A COLTELLI PER SPIANARE IN HM D=70X20 Z=4 SHANK 20X50 - DISEGNO 85635 DX
1	A0694.025.81586	PUNTE PER FORI CIECHI IN HM Z2+2 ATTACCO 10X20 D5X45X70 DX
1	A0694.026.81587	PUNTE PER FORI CIECHI IN HM Z2+2 ATTACCO 10X20 D5X45X70 SX
1	A0694.031.81592	PUNTE PER FORI CIECHI IN HM Z2+2 ATTACCO 10X20 D8X45X70 DX
1	A0694.032.81593	PUNTE PER FORI CIECHI IN HM Z2+2 ATTACCO 10X20 D8X45X70 SX
1	A0694.035.81596	PUNTE PER FORI CIECHI IN HM Z2+2 ATTACCO 10X20 D10X45X70 DX
1	A0694.036.81597	PUNTE PER FORI CIECHI IN HM Z2+2 ATTACCO 10X20 D10X45X70 SX
1	A0696.009.81614	PUNTE PER FORI PASSANTI IN HM Z2+2 ATTACCO 10X20 D5X50X70 DX
1	A0696.010.81615	PUNTE PER FORI PASSANTI IN HM Z2+2 ATTACCO 10X20 D5X50X70 SX
1	A0696.013.81618	PUNTE PER FORI PASSANTI IN HM Z2+2 ATTACCO 10X20 D8X50X70 DX
1	A0696.014.81619	PUNTE PER FORI PASSANTI IN HM Z2+2 ATTACCO 10X20 D8X50X70 SX
1	A0696.015.81620	PUNTE PER FORI PASSANTI IN HM Z2+2 ATTACCO 10X20 D10X50X70 DX
1	A0696.016.81621	PUNTE PER FORI PASSANTI IN HM Z2+2 ATTACCO 10X20 D10X50X70 SX
1	A0685.039.81554	PUNTA LEVANODI IN HM Z2+2 D35X70 S=10X38 DX
1	A1030.028.81890	PINZA ER32 D16/15
1	A1030.032.81894	PINZA ER32 D20/19
1	A1020.001.81835	ATTACCO HSK63F ER32 DX
QTY.	ART.CODE.DRW	DESCRIPTION
1	A0428.011.28168	HW (INTEGRAL TUNGSTEN CARBIDE) HELICAL ROUTER BIT D16X52X100 Z3+R RH POS
1	A2108.007.89550	PCD HELICOIDAL SHANK CUTTER Z1+1 - STEEL BODY - PCD h2,5 mm D16X27 Z3+1 SHANK 20X50 RH
1	A0485.008.96048	MULTIPROFILE INSERT ROUTER IN HM Z=1 D=24 B=25 SHANK 20X50 RH - WITH 3 SET PROFILED KNIVES CODE 96058 - 96059 - 96060
1	A0493.002.85635	PLANING INSERT ROUTER BITS IN HM D=70X20 Z=4 SHANK 20X50 RH
1	A0694.025.81586	SLOT DOWEL DRILL BITS IN HM Z2+2 SHANK 10X20 D5X45X70 RH
1	A0694.026.81587	SLOT DOWEL DRILL BITS IN HM Z2+2 SHANK 10X20 D5X45X70 LH
1	A0694.031.81592	SLOT DOWEL DRILL BITS IN HM Z2+2 SHANK 10X20 D8X45X70 RH
1	A0694.032.81593	SLOT DOWEL DRILL BITS IN HM Z2+2 SHANK 10X20 D8X45X70 LH
1	A0694.035.81596	SLOT DOWEL DRILL BITS IN HM Z2+2 SHANK 10X20 D10X45X70 RH
1	A0694.036.81597	SLOT DOWEL DRILL BITS IN HM Z2+2 SHANK 10X20 D10X45X70 LH
1	A0696.009.81614	THROUGH HOLE DOWEL DRILL BITS IN HM Z2+2 SHANK 10X20 D5X50X70 RH
1	A0696.010.81615	THROUGH HOLE DOWEL DRILL BITS IN HM Z2+2 SHANK 10X20 D5X50X70 LH
1	A0696.013.81618	THROUGH HOLE DOWEL DRILL BITS IN HM Z2+2 SHANK 10X20 D8X50X70 RH
1	A0696.014.81619	THROUGH HOLE DOWEL DRILL BITS IN HM Z2+2 SHANK 10X20 D8X50X70 LH
1	A0696.015.81620	THROUGH HOLE DOWEL DRILL BITS IN HM Z2+2 SHANK 10X20 D10X50X70 RH
1	A0696.016.81621	THROUGH HOLE DOWEL DRILL BITS IN HM Z2+2 SHANK 10X20 D10X50X70 LH
1	A0685.039.81554	HINGE DRILL BITS IN HM Z2+2 D35X70 S=10X38 RH
1	A1030.028.81890	ER COLLECT ER32 D16/15
1	A1030.032.81894	ER COLLECT ER32 D20/19
1	A1020.001.81835	COLLET HOLDERS HSK63F ER32 RH

### DATI TECNICI / TECHNICAL DATA

ART	COD	DRW
A2140	001	96047