

## Accessori - Accessories

A2161 - Mandrino portalama con attacco hsk63f per lame circolari <i>A2161 - Blade holder chuck with hsk63f connection for circular blades</i>	pag. 1
A1015 - Alberini attacco cilindrico <i>A1015 - Tool holders</i>	pag. 2
A1016 - Alberino porta lama con foro centrale porta punta <i>A1016 -</i>	pag. 3
A1020 - Mandrini porta pinza hsk 63 f <i>A1020 - Hsk 63 f collet holders</i>	pag. 4
A1024 - Mandrini porta pinza iso 30 <i>A1024 - Collet holders iso 30</i>	pag. 5
A1026 - Mandrini porta pinza iso 40 <i>A1026 - Collet holders iso 40</i>	pag. 6
A2142 - Mandrino alberato hsk 63 f <i>A2142 - Hsk 63f shank</i>	pag. 7
A2143 - Mandrino alberato iso 30 <i>A2143 - Iso 30 shank</i>	pag. 10
A1030 - Pinze elastiche er <i>A1030 - Er collects</i>	pag. 12
A2136 - Pinze elastiche eoc <i>A2136 - Eoc collects</i>	pag. 14
A2139 - Convogliatore a ghiera <i>A2139 - Conveyor clamping nut</i>	pag. 15
A2159 - Flangia a cappello maschio per chiusura su albero <i>A2159 - Male cap flange for closure on the shaft</i>	pag. 16
A2160 - Flangia a cappello femmina per chiusura su albero <i>A2160 - Female cap flange for closure on the shaft</i>	pag. 17
A1043 - Boccole di assemblaggio <i>A1043 - Sleeves</i>	pag. 18
A1045 - Bussole di riduzione con flangia <i>A1045 - Reduction bushes with flange</i>	pag. 19
A1046 - Bussole di riduzione a tubo <i>A1046 - Cylindrical reduction bushes</i>	pag. 20
A1047 - Anelli di riduzione per lame <i>A1047 - Reduction rings for saw blades</i>	pag. 21
A1057 - Tasselli di bloccaggio radiale	pag. 22

<i>A1057 - Wedges for radial clamping</i>	
A1058 - Tasselli di bloccaggio frontali <i>A1058 - Front locking wedges</i>	pag. 24
A1059 - Tasselli di bloccaggio trafilati 15° <i>A1059 - Drawn locking wedges 15°</i>	pag. 25
A2118 - Tasselli di bloccaggio trafilati 36° <i>A2118 - Drawn locking wedges 36°</i>	pag. 27
A1060 - Blocchetti regolabili porta inserti <i>A1060 - Adjustable insert holder</i>	pag. 28
A1065 - Ghiere per frese a spessore sottile <i>A1065 - Locking nuts for thin cutter blocks</i>	pag. 29
A1070 - Grani di serraggio con codolo cilindrico <i>A1070 - Cylindrical shank grub screw</i>	pag. 30
A1072 - Viti testa svasata con esagono incassato <i>A1072 - Flared head screw with hexag. recess</i>	pag. 31
A1075 - Viti a testa bombata con impronta torx <i>A1075 - Convex head screws with torx recess</i>	pag. 32
A1077 - Viti di battuta <i>A1077 - Screws for insert location</i>	pag. 33
A1078 - Viti testa conica per tasselli radiali <i>A1078 - Conical head screws for radial edges</i>	pag. 34
A1079 - Viti a testa bombata con esagono incassato <i>A1079 - Convex head screw with hexagonal recess</i>	pag. 35
A1080 - Viti a testa cilindrica con esagono incassato <i>A1080 - Cylindrical head screw with hexagonal recess</i>	pag. 36
A1081 - Vite testa svasata con impronta torx <i>A1081 - Flared head screw with torx recess</i>	pag. 37
A1082 - Viti testa svasata con impronta torx e codolo di centraggio <i>A1082 - Flared head screw with torx recess and centring shank</i>	pag. 38
A2119 - Ingrassatori con guarnizione per sistema hydro <i>A2119 - Hydro elements</i>	pag. 39
A2120 - Valvole di deflusso per sistema hydro <i>A2120 - Hydro elements</i>	pag. 40
A2121 - Pompe ad alta pressione per sistema hydro <i>A2121 - Hydro pumps</i>	pag. 41
A2122 - Cartucce di grasso per pompa sistema hydro	pag. 42

*A2122 - Grease for hydro pump*

A1090 - Chiavi a brugola a pag. 43  
*A1090 - Allen*

A1091 - Chiavi a brugola forma a "t" pag. 44  
*A1091 - Allen*

A2153 - Chiave smonta ghiera pag. 45  
*A2153 - Ring remover key*

A1094 - Chiavi torx a cacciavite pag. 46  
*A1094 - Torx key screwdriver*

A2127 - Morsa smontaconi per mandrini portapinza pag. 47  
*A2127 - Adjustable demount devices for tool holders*

## A2161

Mandrino portalama con attacco hsk63f per lame circolari

*Blade holder chuck with hsk63f connection for circular blades*



### INFO ORDINE / ORDER INFO

E' compatibile con una lama dotata di opportuni fori di trascinamento.

*It is compatible with a blade equipped with appropriate drag holes.*

### DESCRIZIONE / DESCRIPTION

Mandrino flangiato per consentire l'istallazione di lame circolari di grande diametro (fino a 300 mm di diametro) su centri di lavoro cnc. Il mandrino è costruito con un perno di centraggio e sei fori filettati che consentono un bloccaggio stabile e sicuro della lama.

*Flanged spindle to allow the installation of large diameter circular blades (up to 300 mm in diameter) on CNC machining centres. The chuck is constructed with a centering pin and six threaded holes that allow for stable and secure locking of the blade.*

### DATI TECNICI / TECHNICAL DATA

ART	COD	DRW	D	LTT	d
A2161	001	98445	110	125	30
A2161	001	98445	110	125	30



# A1015

Alberini attacco cilindrico

*Tool holders*

## IMPIEGO / FUNCTION

Centro di lavoro cnc  
*cnc router*

## DESCRIZIONE / DESCRIPTION

Esecuzione in Acciaio ad alta resistenza. Superfici di accoppiamento totalmente rettificate. La flangia e le viti di bloccaggio sono incluse. Questo articolo è concepito per utilizzare frese con foro su centri di lavoro.

*High resistance stell made. Totally refaced surfaces. Screws and flanges included. This tool is designed to use cutters with hole on machining centers.*

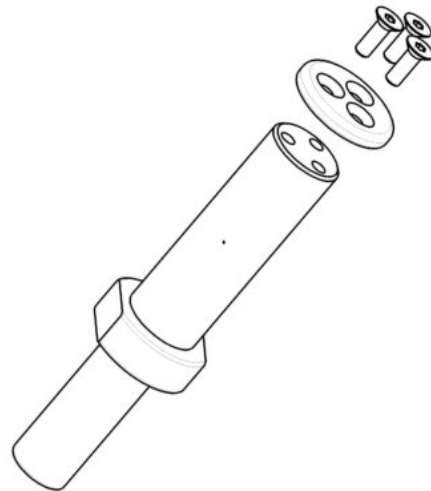
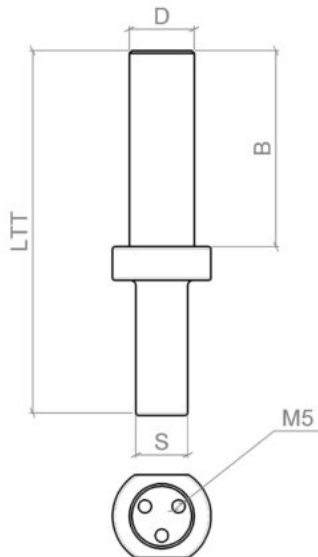

## DATI TECNICI / TECHNICAL DATA

ART	COD	DRW	D	B	RT	S
A1015	025	22436	25	60	122,5	20
A1015	026	22437	25	60	122,5	25
A1015	027	11768	25	75	140,5	20
A1015	028	22435	25	75	140,5	25



## A1016

Alberino porta lama con foro centrale porta punta

### IMPIEGO / FUNCTION

centro lavoro cnc  
cnc router

### DESCRIZIONE / DESCRIPTION

FORNITO CON 4 VITI PER IL FISSAGGIO DELLA LAMA

EQUIPPED WITH 4 SCREWS FOR FIXING SAW BALDE

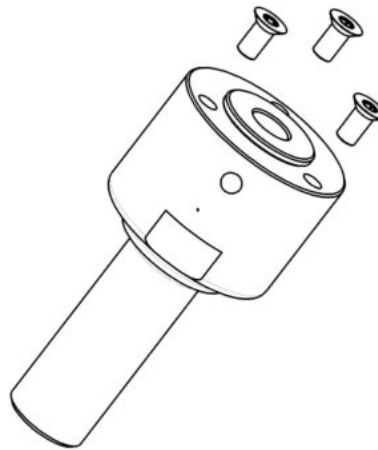
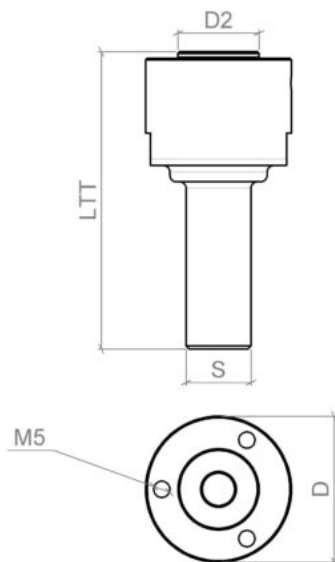

### DATI TECNICI / TECHNICAL DATA

ART	COD	DRW	D	LTT	D2	S
A1016	001	2988	45	91.5	10	20
A1016	002	34710	45	91.5	10	25

## A1020

Mandrini porta pinza hsk 63 f  
Hsk 63 f collet holders



### DESCRIZIONE / DESCRIPTION

Portautensili per utensili a stelo cilindrico Particolarmente indicati nelle lavorazioni con esalazioni di vapore che li possono fortemente intaccare, come ad esempio nella lavorazione di legni resinoidi e materiali composti o nelle lavorazioni in ambienti umidi. Bilanciato per lavorare fino a 24000 RPM. Il portautensile viene fornito completo di ghiera

*Tool Holders for round shank tools Particularly suitable for processing with steam fumes that can severely affect them, such as for example in the processing of resinoid woods and composite materials or in processing in humid environments. Balanced to work up to 24000 RPM. chuck is supplied complete with nut*

### DATI TECNICI / TECHNICAL DATA

ART	COD	DRW	D	d	ROT	RIF
A1020	001	81835	63	38	Dx Rh	ER 32
A1020	002	81836	63	38	Sx Lh	ER 32
A1020	003	81837	63	38	Dx Rh	ER 40
A1020	004	81838	63	38	Sx Lh	ER 40



## A1024

Mandrini porta pinza iso 30  
Collet holders iso 30

### DESCRIZIONE / DESCRIPTION

Portautensili per utensili a stelo cilindrico costruito interamente in acciaio inox per risolvere definitivamente qualsiasi problema di ossidazione, garantendo altissima resistenza ed estrema affidabilità. Bilanciato per lavorare fino a 24000 RPM. Il mandrino è compatibile con le macchine Biesse (dopo il 09/09/92) Masterwood - Bulleri con motori HSD con pinze ER40. Il portautensile viene fornito completo di ghiera e tirante (senza pinza).

*Tool Holders for round shank tools built entirely in stainless steel to definitively solve any oxidation problem, guaranteeing very high resistance and extreme reliability. Balanced to work up to 24000 RPM. The spindle is compatible with Biesse machines (after 09/09/92) Masterwood - Bulleri with HSD motors with ER32 collets. The tool holder is supplied complete with nut and tie rod (without collet)*

### DATI TECNICI / TECHNICAL DATA

ART	COD	DRW	ROT	RIF
A1024	001	81851	Dx Rh	ER32
A1024	002	81852	Sx Lh	ISO 30
A1024	003	81853	Dx Rh	ER40
A1024	004	81854	Sx Lh	ISO 30





## A1026

Mandrini porta pinza iso 40  
Collet holders iso 40

### DESCRIZIONE / DESCRIPTION

Portautensili per utensili a stelo cilindrico costruito interamente in acciaio inox per risolvere definitivamente qualsiasi problema di ossidazione, garantendo altissima resistenza ed estrema affidabilità. Bilanciato per lavorare fino a 24000 RPM. Il mandrino è compatibile con le macchine Biesse (dopo il 09/09/92) Masterwood - Bulleri con motori HSD con pinze ER40. Il portautensile viene fornito completo di ghiera e tirante (senza pinza).

*Tool Holders for round shank tools built entirely in stainless steel to definitively solve any oxidation problem, guaranteeing very high resistance and extreme reliability. Balanced to work up to 24000 RPM. The spindle is compatible with Biesse machines (after 09/09/92) Masterwood - Bulleri with HSD motors with ER32 collets. The tool holder is supplied complete with nut and tie rod (without collet)*

### DATI TECNICI / TECHNICAL DATA

ART	COD	DRW	ROT	RIF	W	Q	U
A1026	001	81859	Dx Rh	ISO 40	2	8	4
A1026	002	81860	Sx Lh	ISO 40	2	8	4
A1026	003	81861	Dx Rh	ISO 40	0	0	0
A1026	004	81862	Sx Lh	ISO 40	0	0	0



## A2142

Mandrino alberato hsk 63 f

*Hsk 63f shank*

### INFO ORDINE / ORDER INFO

La flangia di bloccaggio fornita come standard è quella articolo A2159. Il mandrino è compatibile anche con l'articolo A2160, indicare in fase di ordine l'eventuale preferenza.

*The locking flange supplied as standard is item A2159. The chuck is also compatible with article A2160, indicate any preference when ordering.*

### DESCRIZIONE / DESCRIPTION

Mandrino alberato per il montaggio di utensili o gruppi di utensili con foro su centri di lavoro CNC.

*Shafted spindle for mounting tools or tool assemblies with hole on CNC machining centres.*

### DATI TECNICI / TECHNICAL DATA

ART	COD	DRW	D	B
A2142	001	96177	30	50
A2142	002	96178	30	55
A2142	003	96179	30	60
A2142	004	96180	30	65
A2142	005	96181	30	70
A2142	006	96182	30	75
A2142	007	96183	30	80
A2142	008	96184	30	85
A2142	009	96185	30	90
A2142	010	96186	30	95
A2142	011	96187	30	100
A2142	012	96188	30	105
A2142	013	96189	30	110
A2142	014	96190	30	115
A2142	015	96191	30	120
A2142	016	96192	30	125
A2142	017	96193	30	130
A2142	018	96194	30	135
A2142	019	96195	30	140
A2142	020	96196	30	145
A2142	021	96197	30	150
A2142	022	96198	30	155
A2142	023	96199	30	160
A2142	024	96200	30	165
A2142	025	96201	30	170
A2142	026	96202	30	175
A2142	027	96203	30	180
A2142	028	96204	30	185
A2142	029	96205	30	190
A2142	030	96206	30	195
A2142	031	96207	30	200
A2142	032	96208	35	50
A2142	033	96209	35	55
A2142	034	96210	35	60
A2142	035	96211	35	65

ART	COD	DRW	D	B
A2142	036	96212	35	70
A2142	037	96213	35	75
A2142	038	96214	35	80
A2142	039	96215	35	85
A2142	040	96216	35	90
A2142	041	96217	35	95
A2142	042	96218	35	100
A2142	043	96219	35	105
A2142	044	96220	35	110
A2142	045	96221	35	115
A2142	046	96222	35	120
A2142	047	96223	35	125
A2142	048	96224	35	130
A2142	049	96225	35	135
A2142	050	96226	35	140
A2142	051	96227	35	145
A2142	052	96228	35	150
A2142	053	96229	35	155
A2142	054	96230	35	160
A2142	055	96231	35	165
A2142	056	96232	35	170
A2142	057	96233	35	175
A2142	058	96234	35	180
A2142	059	96235	35	185
A2142	060	96236	35	190
A2142	061	96237	35	195
A2142	062	96238	35	200
A2142	063	96239	40	50
A2142	064	96240	40	55
A2142	065	96241	40	60
A2142	066	96242	40	65
A2142	067	96243	40	70
A2142	068	96244	40	75
A2142	069	96245	40	80
A2142	070	96246	40	85
A2142	071	96247	40	90
A2142	072	96248	40	95
A2142	073	96249	40	100
A2142	074	96250	40	105
A2142	075	96251	40	110
A2142	076	96252	40	115
A2142	077	96253	40	120
A2142	078	96254	40	125
A2142	079	96255	40	130
A2142	080	96256	40	135
A2142	081	96257	40	140
A2142	082	96258	40	145
A2142	083	96259	40	150
A2142	084	96260	40	155
A2142	085	96261	40	160
A2142	086	96262	40	165
A2142	087	96263	40	170
A2142	088	96264	40	175
A2142	089	96265	40	180
A2142	090	96266	40	185
A2142	091	96267	40	190

<b>ART</b>	<b>COD</b>	<b>DRW</b>	<b>D</b>	<b>B</b>
A2142	092	96268	40	195
A2142	093	96269	40	200



## A2143

Mandrino alberato iso 30

*Iso 30 shank*

### INFO ORDINE / ORDER INFO

La flangia di bloccaggio fornita come standard è quella articolo A2159. Il mandrino è compatibile anche con l'articolo A2160, indicare in fase di ordine l'eventuale preferenza.

*The locking flange supplied as standard is item A2159. The chuck is also compatible with article A2160, indicate any preference when ordering.*

### DESCRIZIONE / DESCRIPTION

Mandrino alberato per il montaggio di utensili o gruppi di utensili con foro su centri di lavoro CNC.

*Shafted spindle for mounting tools or tool assemblies with hole on CNC machining centres.*

### DATI TECNICI / TECHNICAL DATA

ART	COD	DRW	D	B
A2143	001	96281	30	50
A2143	002	96282	30	55
A2143	003	96283	30	60
A2143	004	96284	30	65
A2143	005	96285	30	70
A2143	006	96286	30	75
A2143	007	96287	30	80
A2143	008	96288	30	85
A2143	009	96289	30	90
A2143	010	96290	30	95
A2143	011	96291	30	100
A2143	012	96292	30	105
A2143	013	96293	30	110
A2143	014	96294	30	115
A2143	015	96295	30	120
A2143	016	96296	30	125
A2143	017	96297	30	130
A2143	018	96298	30	135
A2143	019	96299	30	140
A2143	020	96300	30	145
A2143	021	96301	30	150
A2143	022	96302	30	155
A2143	023	96303	30	160
A2143	024	96304	30	165
A2143	025	96305	30	170
A2143	026	96306	30	175
A2143	027	96307	30	180
A2143	028	96308	30	185
A2143	029	96309	30	190
A2143	030	96310	30	195
A2143	031	96311	30	200
A2143	032	96312	35	50
A2143	033	96313	35	55
A2143	034	96314	35	60
A2143	035	96315	35	65

ART	COD	DRW	D	B
A2143	036	96316	35	70
A2143	037	96317	35	75
A2143	038	96318	35	80
A2143	039	96319	35	85
A2143	040	96320	35	90
A2143	041	96321	35	95
A2143	042	96322	35	100
A2143	043	96323	35	105
A2143	044	96324	35	110
A2143	045	96325	35	115
A2143	046	96326	35	120
A2143	047	96327	35	125
A2143	048	96328	35	130
A2143	049	96329	35	135
A2143	050	96330	35	140
A2143	051	96331	35	145
A2143	052	96332	35	150
A2143	053	96333	35	155
A2143	054	96334	35	160
A2143	055	96335	35	165
A2143	056	96336	35	170
A2143	057	96337	35	175
A2143	058	96338	35	180
A2143	059	96339	35	185
A2143	060	96340	35	190
A2143	061	96341	35	195
A2143	062	96342	35	200

# A1030

Pinze elastiche er  
*Er collects*



## DESCRIZIONE / DESCRIPTION

## DATI TECNICI / TECHNICAL DATA

ART	COD	DRW	d	RIF
A1030	001	81863	3-2	ER 25
A1030	002	81864	4-3	ER 25
A1030	003	81865	5-4	ER 25
A1030	004	81866	6-5	ER 25
A1030	005	81867	7-6	ER 25
A1030	006	81868	8-7	ER 25
A1030	007	81869	9-8	ER 25
A1030	008	81870	10-9	ER 25
A1030	009	81871	11-10	ER 25
A1030	010	81872	12-11	ER 25
A1030	011	81873	13-12	ER 25
A1030	012	81874	14-13	ER 25
A1030	013	81875	15-14	ER 25
A1030	014	81876	16-15	ER 25
A1030	015	81877	3-2	ER 32
A1030	016	81878	4-3	ER 32
A1030	017	81879	5-4	ER 32
A1030	018	81880	6-5	ER 32
A1030	019	81881	7-6	ER 32
A1030	020	81882	8-7	ER 32
A1030	021	81883	9-8	ER 32
A1030	022	81884	10-9	ER 32
A1030	023	81885	11-10	ER 32
A1030	024	81886	12-11	ER 32
A1030	025	81887	13-12	ER 32
A1030	026	81888	14-13	ER 32
A1030	027	81889	15-14	ER 32
A1030	028	81890	16-15	ER 32
A1030	029	81891	17-16	ER 32
A1030	030	81892	18-17	ER 32
A1030	031	81893	19-18	ER 32
A1030	032	81894	20-19	ER 32
A1030	033	81895	3-2	ER 40
A1030	034	81896	4-3	ER 40
A1030	035	81897	5-4	ER 40
A1030	036	81898	6-5	ER 40
A1030	037	81899	7-6	ER 40

<b>ART</b>	<b>COD</b>	<b>DRW</b>	<b>d</b>	<b>RIF</b>
A1030	038	81900	8-7	ER 40
A1030	039	81901	9-8	ER 40
A1030	040	81902	10-9	ER 40
A1030	041	81903	11-10	ER 40
A1030	042	81904	12-11	ER 40
A1030	043	81905	13-12	ER 40
A1030	044	81906	14-13	ER 40
A1030	045	81907	15-14	ER 40
A1030	046	81908	16-15	ER 40
A1030	047	81909	17-16	ER 40
A1030	048	81910	18-17	ER 40
A1030	049	81911	19-18	ER 40
A1030	050	81912	20-19	ER 40
A1030	051	81913	25-24	ER 40





## A2136

Pinze elastiche eoc  
*Eoc collects*

### DESCRIZIONE / DESCRIPTION

Pinze elastiche DIN6388

*Elastic collects DIN6388*

### DATI TECNICI / TECHNICAL DATA

ART	COD	DRW	D	B	D2
A2136	001	95713	3	52	35
A2136	002	95714	4	52	35
A2136	003	95715	5	52	35
A2136	004	95716	6	52	35
A2136	005	95717	6.35	52	35
A2136	006	95718	8	52	35
A2136	007	95719	9.5	52	35
A2136	008	95720	10	52	35
A2136	009	95721	12	52	35
A2136	010	95722	12.7	52	35
A2136	011	95723	14	52	35
A2136	012	95724	16	52	35
A2136	013	95725	18	52	35
A2136	014	95726	19.05	52	35
A2136	015	95727	20	52	35
A2136	016	95728	25	52	35

## A2139

Convogliatore a ghiera  
*Conveyor clamping nut*

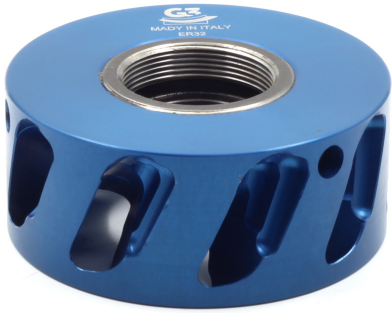

### DESCRIZIONE / DESCRIPTION

Convogliatore ad elica che sostituisce la ghiera di fissaggio del portapinze estraendo i trucioli e la polvere di lavorazione durante il processo e la indirizza verso la bocca di aspirazione della macchina.

*helix conveyor which replaces the collet holder fixing ring by extracting the shavings and machining dust during the process and directs it towards the suction mouth of the machine.*

### DATI TECNICI / TECHNICAL DATA

ART	COD	DRW	D	B	RIF
A2139	002	95916	80	40	ER32
A2139	3	95917	80	40	ER40

## A2159

Flangia a cappello maschio per chiusura su albero

*Male cap flange for closure on the shaft*



### DESCRIZIONE / DESCRIPTION

Flangia di chiusura ambidestra con serraggio mediante 3 viti m6

*Ambidextrous closing flange with tightening using 3 m6 screws*

### DATI TECNICI / TECHNICAL DATA

ART	COD	DRW	D	B	D2	K
A2159	001	40113	30	10	40	3



## A2160

Flangia a cappello femmina per chiusura su albero

*Female cap flange for closure on the shaft*

### DESCRIZIONE / DESCRIPTION

Flangia di chiusura ambidestra con serraggio mediante 3 viti m6

*Ambidextrous closing flange with tightening using 3 m6 screws*

### DATI TECNICI / TECHNICAL DATA

ART	COD	DRW	D	B	D2	K
A2160	001	48313	30	13	40	3



## A1043

Boccole di assemblaggio  
Sleeves

### DESCRIZIONE / DESCRIPTION

Compresa di ghiera di serraggio.

*Tightening nut included*

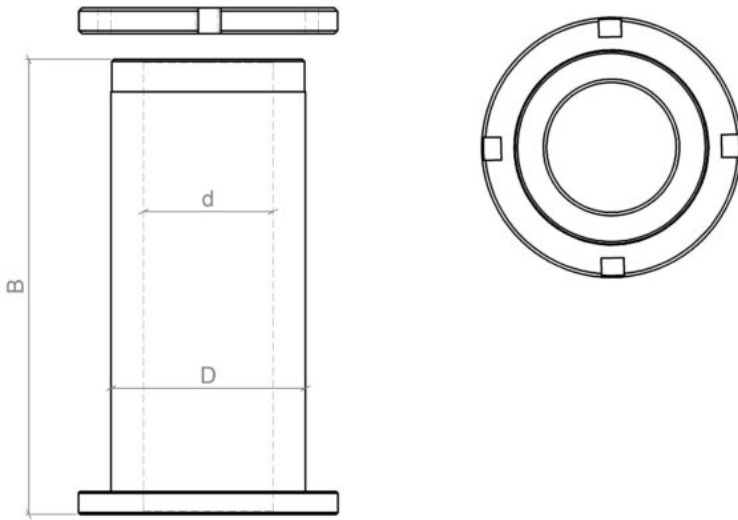

### DATI TECNICI / TECHNICAL DATA

ART	COD	DRW	D	B	d	ROT
A1043	001	81926	50	95	35	Dx Rh
A1043	002	81927	50	95	35	Sx Lh
A1043	004	81929	50	95	40	Sx Lh
A1043	005	81930	60	95	35	Dx Rh
A1043	006	81931	60	95	35	Sx Lh
A1043	007	81932	60	95	40	Dx Rh
A1043	008	81933	60	95	40	Sx Lh
A1043	009	81934	60	95	50	Dx Rh
A1043	010	81935	60	95	50	Sx Lh
A1043	003	8816	50	95	40	Dx Rh

## A1045

Bussole di riduzione con flangia  
Reduction bushes with flange

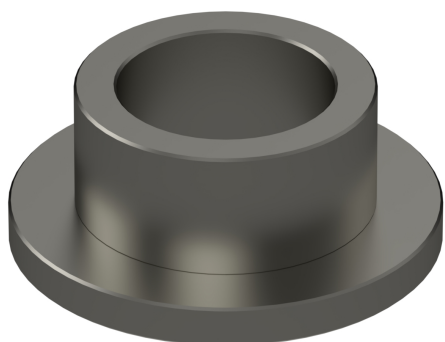

### DESCRIZIONE / DESCRIPTION

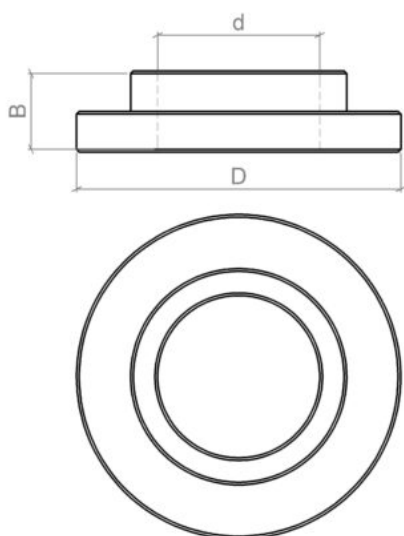

### DATI TECNICI / TECHNICAL DATA

ART	COD	DRW	D	B	d	RIF
A1045	004	81943	35	15	30	55
A1045	005	81944	40	15	30	60
A1045	006	81945	40	15	35	55
A1045	007	81946	50	15	30	70
A1045	008	81947	50	15	35	70
A1045	009	81948	50	15	40	70



## A1046

Bussole di riduzione a tubo  
*Cylindrical reduction bushes*

### DESCRIZIONE / DESCRIPTION

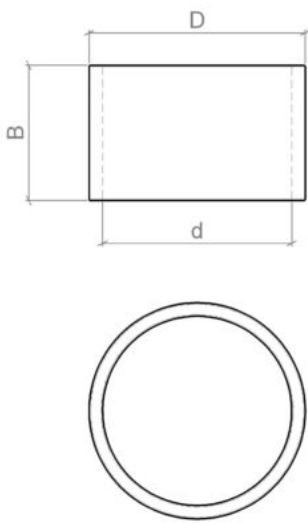

### DATI TECNICI / TECHNICAL DATA

ART	COD	DRW	D	B	d
A1046	006	81954	35	5	30
A1046	007	81955	35	10	30
A1046	008	81956	35	20	30
A1046	009	81957	35	30	30
A1046	010	81958	35	40	30
A1046	011	81959	40	5	35
A1046	012	81960	40	10	35
A1046	013	81961	40	20	35
A1046	014	81962	40	30	35
A1046	015	81963	40	40	35

# A1047

Anelli di riduzione per lame  
Reduction rings for saw blades

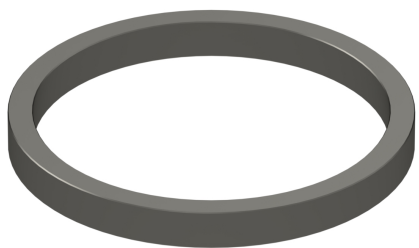

## DESCRIZIONE / DESCRIPTION

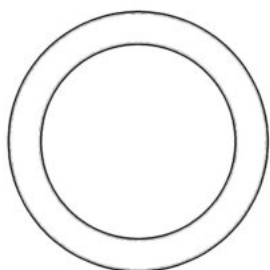

## DATI TECNICI / TECHNICAL DATA

ART	COD	DRW	D	B	d
A1047	001	81969	20	2.1	16
A1047	004	81972	25	2.1	20
A1047	006	81974	30	2.1	16
A1047	007	81975	30	2.1	20
A1047	009	81977	30	2.1	25
A1047	010	81978	32	2.1	20
A1047	012	81980	32	2.1	30
A1047	013	81981	35	2.1	20
A1047	014	81982	35	2.1	25
A1047	015	81983	35	2.1	30
A1047	016	81984	35	2.1	32
A1047	019	81987	40	2.1	30
A1047	020	81988	40	2.1	32
A1047	021	81989	40	2.1	35



# A1057

Tasselli di bloccaggio radiale  
*Wedges for radial clamping*



## DESCRIZIONE / DESCRIPTION

Tassello di fissaggio in Acciaio al carbonio per il fissaggio degli inserti. Compatibile con le viti articolo A

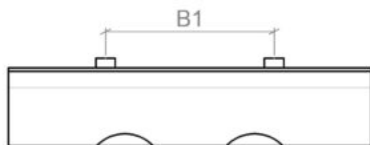
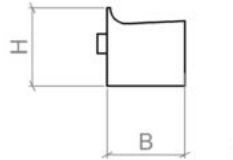
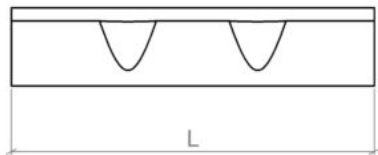

## DATI TECNICI / TECHNICAL DATA

ART	COD	DRW	B	B1	L	H	RIF
A1057	010	5261	12	0	16	12	1 spina/pin
A1057	011	11242	12	0	21	12	1 spina/pin
A1057	012	5425	12	14	26	12	2 spine/pins
A1057	013	11240	12	14	31	12	2 spine/pins
A1057	014	5428	12	26	36	12	2 spine/pins
A1057	015	5710	12	26	46	12	2 spine/pins
A1057	016	5242	12	26	56	12	2 spine/pins
A1057	017	10040	12	26	76	12	2 spine/pins
A1057	018	6020	12	60	76	12	2 spine/pins
A1057	019	15296	12	0	21	12	1 spina/pin - Asola decentrata
A1057	020	15998	6	0	7	10	1 spina/pin
A1057	021	15806	6	0	10	10	1 spina/pin
A1057	022	15751	6	0	17	10	1 spina/pin
A1057	023	15752	6	0	23	10	1 spina/pin
A1057	024	15598	6	14	28	10	2 spine/pins
A1057	025	16569	6	26	38	10	2 spine/pins
A1057	026	15604	6	26	48	10	2 spine/pins

<b>ART</b>	<b>COD</b>	<b>DRW</b>	<b>B</b>	<b>B1</b>	<b>L</b>	<b>H</b>	<b>RIF</b>
A1057	027	10865	6	26	58	10	2 spine/pins
A1057	028	92089	6	26	78	10	2 spine/pins

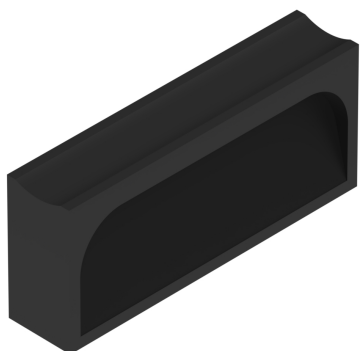

## A1058

Tasselli di bloccaggio frontali  
*Front locking wedges*

### DESCRIZIONE / DESCRIPTION

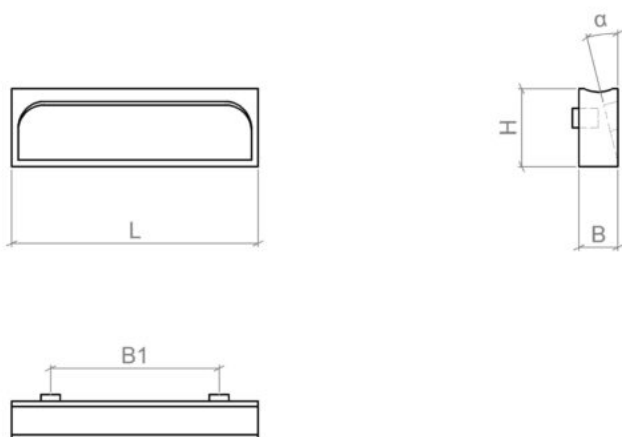

### DATI TECNICI / TECHNICAL DATA

ART	COD	DRW	B	B1	L	H	RIF	ALFA
A1058	010	38087	6	0	12	10	1 spina/pin	14
A1058	011	40835	6	0	18	10	1 spina/pin	14
A1058	012	3252	6	14	28	10	2 spine/pins	14
A1058	013	3254	6	26	38	10	2 spine/pins	14
A1058	014	3256	6	26	48	10	2 spine/pins	14
A1058	015	40834	6	26	58	10	2 spine/pins	14

# A1059

Tasselli di bloccaggio trafilati 15°  
*Drawn locking wedges 15°*

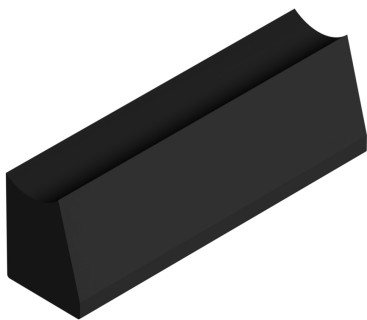

## DESCRIZIONE / DESCRIPTION

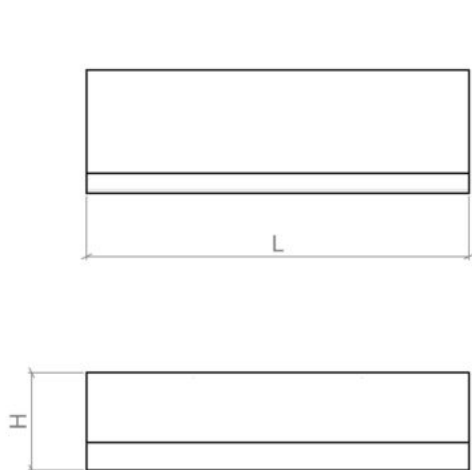

## DATI TECNICI / TECHNICAL DATA

ART	COD	DRW	B	L	H	ALFA
A1059	001	23009	15	39	19	15
A1059	002	28414	15	49	19	15
A1059	003	23694	15	59	19	15
A1059	004	35298	15	69	19	15
A1059	005	23016	15	79	19	15
A1059	006	31829	15	89	19	15
A1059	007	23852	15	99	19	15
A1059	008	30792	15	119	19	15
A1059	009	19413	15	129	19	15
A1059	010	28393	15	139	19	15
A1059	011	23942	15	149	19	15
A1059	012	28262	15	159	19	15
A1059	013	26885	15	169	19	15
A1059	014	24689	15	179	19	15
A1059	015	28491	15	189	19	15
A1059	016	26587	15	199	19	15
A1059	017	26458	15	209	19	15
A1059	018	25808	15	219	19	15
A1059	019	23941	15	229	19	15

<b>ART</b>	<b>COD</b>	<b>DRW</b>	<b>B</b>	<b>L</b>	<b>H</b>	<b>ALFA</b>
A1059	020	28282	15	239	19	15
A1059	021	28295	15	249	19	15
A1059	022	28256	15	259	19	15
A1059	023	17642	15	269	19	15
A1059	024	84229	15	309	19	15
A1059	025	86212	15	329	19	15

# A2118

Tasselli di bloccaggio trafilati 36°

*Drawn locking wedges 36°*



## DESCRIZIONE / DESCRIPTION

## DATI TECNICI / TECHNICAL DATA

ART	COD	DRW	B	L	H	ALFA
A2118	001	25828	10	39	20	36
A2118	002	41859	10	49	20	36
A2118	003	25829	10	59	20	36
A2118	004	87908	10	69	20	36
A2118	005	25830	10	79	20	36
A2118	006	87909	10	89	20	36
A2118	007	25831	10	99	20	36
A2118	008	25832	10	119	20	36
A2118	009	25833	10	129	20	36
A2118	010	34250	10	139	20	36
A2118	011	25834	10	149	20	36
A2118	012	25835	10	159	20	36
A2118	013	25836	10	169	20	36
A2118	014	25837	10	179	20	36
A2118	015	87910	10	189	20	36
A2118	016	25838	10	199	20	36
A2118	017	30663	10	209	20	36
A2118	018	40748	10	219	20	36
A2118	019	40373	10	229	20	36
A2118	020	31805	10	239	20	36
A2118	021	87912	10	249	20	36
A2118	022	87913	10	259	20	36
A2118	023	26936	10	309	20	36
A2118	024	87911	10	329	20	36

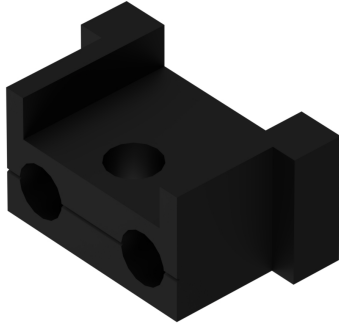

## A1060

Blocchetti regolabili porta inserti  
*Adjustable insert holder*

### DESCRIZIONE / DESCRIPTION

### DATI TECNICI / TECHNICAL DATA

ART	COD	DRW	B	L	H
A1060	010	4141	12	15	15
A1060	011	5599	12	15	25
A1060	012	4339	15	10	24

# A1065

Ghiere per frese a spessore sottile  
*Locking nuts for thin cutter blocks*

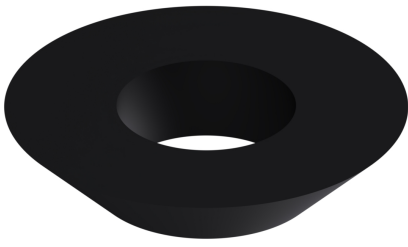

## DESCRIZIONE / DESCRIPTION

## DATI TECNICI / TECHNICAL DATA

ART	COD	DRW	B	D2	RIF
A1065	010	38128	1.9	9	M4
A1065	011	38129	1.1	10.2	M4
A1065	012	38130	2.7	11.8	M4
A1065	013	42288	1.5	11.6	M4





## A1070

Grani di serraggio con codolo cilindrico  
Cylindrical shank grub screw

### DESCRIZIONE / DESCRIPTION

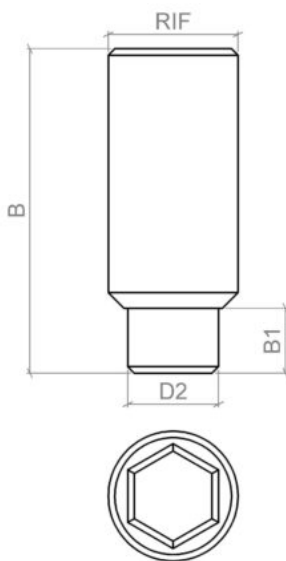

### DATI TECNICI / TECHNICAL DATA

ART	COD	DRW	B	B1	D2	REG	RIF
A1070	001	35435	10	2	3.5		M5
A1070	003	4142	16	2	3.5		M5
A1070	004	4344	10	3	4		M6
A1070	020	4124	16	3	4		M6
A1070	010	4345	16	4	5.6		M8
A1070	021	23006	25	4	5.6		M8
A1070	012	32874	20	5	7	N m 12	M10
A1070	022	4343	25	5	7	N m 12	M10
A1070	023	32188	25	6	8.5		M12



## A1072

Viti testa svasata con esagono incassato  
*Flared head screw with hexag. recess*

### DESCRIZIONE / DESCRIPTION

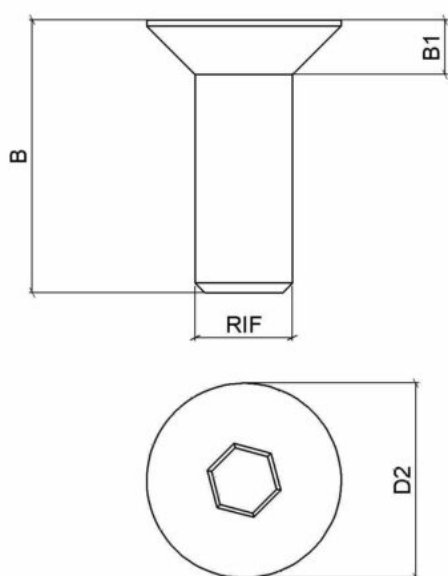

### DATI TECNICI / TECHNICAL DATA

ART	COD	DRW	B	B1	D2	RIF
A1072	009	4459	6	2.8	10	M5
A1072	001	37206	10	2.8	10	M5
A1072	008	37121	14	2.8	10	M5
A1072	007	10500	18	2.8	10	M5
A1072	003	10143	10	3.3	12	M6
A1072	006	23870	20	3.3	12	M6
A1072	005	35469	30	3.3	12	M6



## A1075

Viti a testa bombata con impronta torx  
Convex head screws with torx recess

### DESCRIZIONE / DESCRIPTION

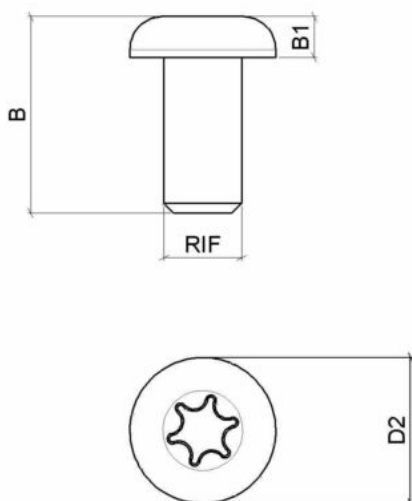

### DATI TECNICI / TECHNICAL DATA

ART	COD	DRW	B	d	B1	D2	RIF
A1075	010	5188	10	7	2.5	7	M3.5
A1075	011	5437	6	7	2.5	7	M3.5
A1075	012	6370	8.5	6	2.2	6	M3.5
A1075	013	15161	8	7.5	2.1	7.5	M4
A1075	014	38251	8	9	2.2	9	M3.5
A1075	015	3452	8	9	2.2	9	M4

# A1077

Viti di battuta

*Screws for insert location*

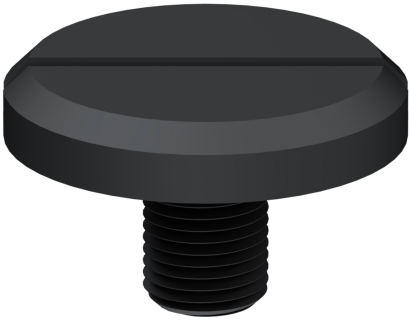

## DESCRIZIONE / DESCRIPTION

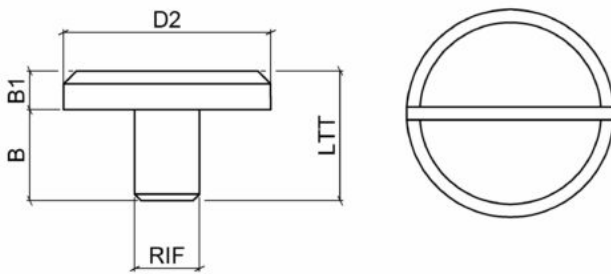

## DATI TECNICI / TECHNICAL DATA

ART	COD	DRW	B	B1	D2	RIF
A1077	010	30871	12	6	5.1	M5
A1077	011	14688	6.5	1	13	M5
A1077	002	2808	10	3	16	M5
A1077	012	2807	10	3	11	M5
A1077	013	2809	8	3	22	M5



## A1078

Viti testa conica per tasselli radiali  
*Conical head screws for radial edges*

### DESCRIZIONE / DESCRIPTION

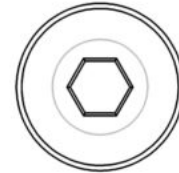
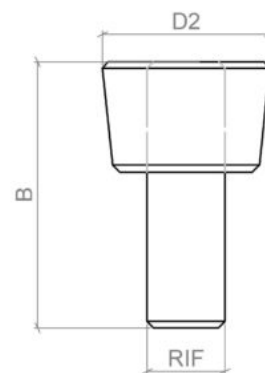
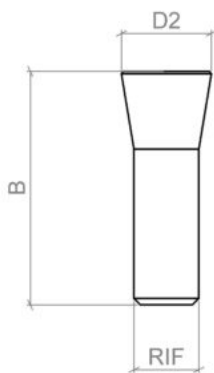

### DATI TECNICI / TECHNICAL DATA

ART	COD	DRW	B	D2	REG	RIF
A1078	010	15999	18	7	N m 8	M5
A1078	011	4833	23	7	N m 8	M5
A1078	012	14700	15	10.2	N m 10	M6
A1078	013	15429	18	10.2	N m 10	M6
A1078	014	6284	22	13	N m 11	M8
A1078	015	6439	19	13	N m 11	M6
A1078	017	26698	10	10	N m 12	M7
A1078	018	26640	19	10	N m 12	M7



## A1079

Viti a testa bombata con esagono incassato  
*Convex head screw with hexagonal recess*

### DESCRIZIONE / DESCRIPTION

### DATI TECNICI / TECHNICAL DATA

ART	COD	DRW	B	B1	D2	RIF
A1079	010	7161	6	1.65	5.5	M3



## A1080

Viti a testa cilindrica con esagono incassato  
*Cylindrical head screw with hexagonal recess*

### DESCRIZIONE / DESCRIPTION

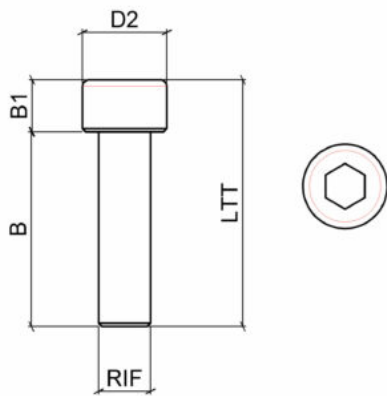

### DATI TECNICI / TECHNICAL DATA

ART	COD	DRW	B	LTT	B1	D2	RIF
A1080	010	5547	30	38	8	13	M8
A1080	011	13402	12	17	8	13	M5



## A1081

Vite testa svasata con impronta torx  
*Flared head screw with torx recess*

### DESCRIZIONE / DESCRIPTION

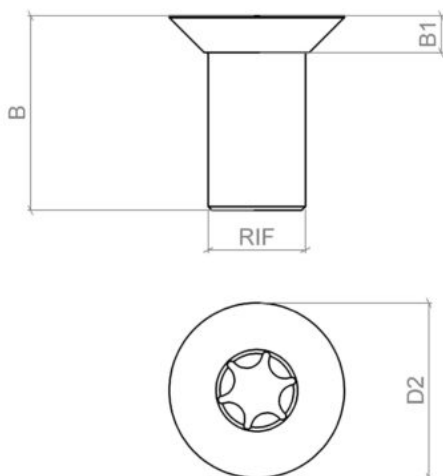

### DATI TECNICI / TECHNICAL DATA

ART	COD	DRW	B	B1	D2	RIF
A1081	001	42287	3.2	1.1	6	M4
A1081	002	34604	4	1.1	6	M4
A1081	003	38127	5	1.1	6	M4
A1081	004	11133	6.5	1.1	6	M4
A1081	005	34356	6.5	1.9	9	M5
A1081	006	34357	10	1.9	9	M5





## A1082

Viti testa svasata con impronta torx e codolo di centraggio

*Flared head screw with torx recess and centring shank*

### DESCRIZIONE / DESCRIPTION

### DATI TECNICI / TECHNICAL DATA

ART	COD	DRW	B	B1	D2	RIF
A1082	001	84452	14	1.4	8.5	M5

## A2119

Ingrassatori con guarnizione per sistema hydro  
*Hydro elements*



### DESCRIZIONE / DESCRIPTION

Ingrassatore in acciaio temprato con valvola per alta pressione completo di guarnizione. Attacco: M10x1  
Pressione di esercizio: 300-700 BAR.

*Tempered steel grease nipple for high pressure with gasket. Connection: M10x1 Work pressure: 300-700 BAR*

### DATI TECNICI / TECHNICAL DATA

ART	COD	DRW
A2119	001	87914

## A2120

Valvole di deflusso per sistema hydro  
*Hydro elements*



### DESCRIZIONE / DESCRIPTION

Valvola di sfiato in acciaio per alta pressione completa di guarnizione. Attacco: M10x1 Pressione di esercizio: 300-700 BAR

*Steel high pressure valve with gasket. Connection M10x1 Work pressure: 300-700 BAR*

### DATI TECNICI / TECHNICAL DATA

ART	COD	DRW
A2120	001	87915



## A2121

Pompe ad alta pressione per sistema hydro  
*Hydro pumps*

### DESCRIZIONE / DESCRIPTION

Pompa manuale ideale per pressioni fino a 700 BAR. Dotata di valvola di non ritorno, di scarico aria e pressione

*The high pressure lever gun is the ideal for pressure up to 700 BAR. Equipped with air relief valve, and pressure relief valve.*

### DATI TECNICI / TECHNICAL DATA

ART	COD	DRW
A2121	001	87916

## A2122

Cartucce di grasso per pompa sistema hydro  
Grease for hydro pump



### DESCRIZIONE / DESCRIPTION

Cartuccia grasso al litio universale per ingrassatori manuali ed aria compressa Temperatura di impiego: fino a 120°

*Universal lithium grease cartridge for compressed air and hand lever pumps Work temperature: up to 120°C*

### DATI TECNICI / TECHNICAL DATA

ART	COD	DRW
A2122	001	87917



## A1090

Chiavi a brugola a  
*Allen*

### DESCRIZIONE / DESCRIPTION

### DATI TECNICI / TECHNICAL DATA

ART	COD	DRW	B
A1090	001	82089	2
A1090	002	82090	2.5
A1090	3	82091	3
A1090	004	82092	4
A1090	005	82093	5
A1090	006	82094	6
A1090	007	82095	8
A1090	008	82096	10

# A1091

Chiavi a brugola forma a "t"  
Allen



## DESCRIZIONE / DESCRIPTION

## DATI TECNICI / TECHNICAL DATA

ART	COD	DRW	B	LTT
A1091	001	82097	2.5	95
A1091	002	82098	3	95
A1091	003	82099	4	95
A1091	004	82100	5	100
A1091	005	82101	6	125
A1091	006	94450	2.5	135
A1091	007	94451	3	135
A1091	008	94452	4	145
A1091	009	94453	5	165
A1091	010	94454	6	180



## A2153

Chiave smonta ghiera  
*Ring remover key*

### DESCRIZIONE / DESCRIPTION

Chiave per il montaggio e smontaggio di ghiera

*Wrench for assembly and disassembly of locknuts*

### DATI TECNICI / TECHNICAL DATA

ART	COD	DRW	RIF
A2153	001	97103	ER 32
A2153	002	97104	ER 40
A2153	003	97105	EOC 25



# A1094

Chiavi torx a cacciavite  
*Torx key screwdriver*



## DESCRIZIONE / DESCRIPTION

## DATI TECNICI / TECHNICAL DATA

ART	COD	DRW	RIF
A1094	010	82110	T9
A1094	011	82111	T15
A1094	012	90983	T20
A1094	013	91014	T25



## A2127

Morsa smontaconi per mandrini portapinza  
Adjustable demount devices for tool holders

### DESCRIZIONE / DESCRIPTION

Il bloccaggio del mandrino avviene attraverso un cuscinetto che protegge l'integrità dello stesso. La morsa è regolabile da 0 a 90° per agevolare l'utilizzo con ogni tipo di utensile. L'apparecchio può essere fissato a qualsiasi banco da lavoro. Ideale per evitare montaggi scorretti degli utensili e infortuni degli operatori.

*The locking of the spindle takes place through a bearing which protects the integrity of the same. The vice is adjustable from 0 to 90° to facilitate use with any type of tool. The device can be fixed to any workbench. Ideal to avoid incorrect tool assembly and operator injuries.*

### DATI TECNICI / TECHNICAL DATA

ART	COD	DRW	D	RIF
A2127	001	95371	32	HSK 32
A2127	002	95372	40	HSK 40
A2127	003	95373	50	ISO30/SK30/HSK50
A2127	004	95374	57	ISO30 Thermowood
A2127	005	95375	58	ISO30 Elte Esseteam
A2127	006	95376	63	HSK 63
A2127	007	95377	63.5	ISO 40